

**BSI**

**BS 6755: Part 2: 1987**

UDC 621.846[620.1:632.11]:614.84

© British Standards Institution. No part of this publication may be photocopied or otherwise reproduced without the prior permission in writing of BSI

---

**British Standard**

# **Testing of valves**

**Part 2. Specification for fire type-testing requirements**

---

**Essais des soupapes**

**Partie 2. Caractéristiques des essais au feu de qualification – Spécifications**

**Prüfung von Ventilen**

**Teil 2. Anforderungen an die Brandschutztypprüfung**

**British Standards Institution**

## Foreword

This British Standard has been prepared under the direction of the Piping Systems Components Standards Committee and is published in two Parts :

Part 1. Specification for production pressure testing requirements

Part 2. Specification for fire type-testing requirements

This Part of BS 6755 embodies the technical content of API Specification 6FA for fire type-testing of valves, including valves to API Specification 6D, and of API Standard 607, published by the American Petroleum Institute (API), but differs in presentation. It covers the requirements for testing and method of test for evaluating the performance of valves when exposed to defined fire conditions. The performance requirements are intended to establish limits of acceptability of a valve regardless of size, nominal pressure (PN) or Class rating. The burn period has been established on the basis that it represents the maximum time required to extinguish most fires. Fires of longer duration are considered to be of a major magnitude with consequences greater than those anticipated in the test.

Permission from API to incorporate the relevant technical content of API Standard 607 and API Specification 6FA into this Part of BS 6755 is gratefully acknowledged.

It is intended that this Part of BS 6755 will eventually supersede the fire test specified in clause 21 and described in appendix A of BS 5146 : Part 1 : 1974. However, to allow for the construction of fire testing equipment and for valve manufacturers to obtain approval for valves made to a fire type-test design the following applies.

(a) For a period of 3 years from the publication of this standard, valves of existing design may be tested in accordance with either:

(1) this Part of BS 6755; or

(2) appendix A of BS 5146 : Part 1 : 1974.

(b) Valves submitted for first time fire type-testing starting from a date 1 year after publication of this Part of BS 6755 should be tested in accordance with this standard.

(c) Three years after publication of this Part of BS 6755, the fire testing requirements given in BS 5146 : Part 1 : 1974 will be withdrawn.

It is intended that this Part of BS 6755 be used in conjunction with the appropriate valve product standard when specified wholly or in part only by the product standard or with a valve application standard, when applicable. In addition, this Part of BS 6755 may be used for the fire type-testing of valves not covered by product standards.

The method for carrying out the fire test is given in appendix A of this Part of BS 6755 and the representative size and pressure range of the valve tested is given in appendix B.

Until such time that sufficient experience is gained with this particular fire test it is not possible to make definitive statements regarding qualification of valves of the same basic design as the test valve, but made using different metals (see note 3 to B.1).

It has been assumed in the drafting of this Part of BS 6755 that the execution of its provisions is entrusted to appropriately qualified and experienced people because it calls for procedures that may be injurious to health if adequate precautions are not taken. It refers only to technical suitability and does not absolve the user from legal obligations relating to health and safety at any stage.

Compliance with a British Standard does not of itself confer immunity from legal obligations.



## Contents

	Page
Foreword	Inside front cover
Committees responsible	Back cover
<b>Section one. General</b>	
1 Scope	2
2 Definitions	2
<b>Section two. Conditions of test</b>	
3 Direction and conditions for valves to be tested	3
4 Pressure relief provision	3
<b>Section three. Performance</b>	
5 General	4
6 Through-seat leakage (high test pressure) during burn period	4
7 External leakage (high test pressure) during burn and cool-down periods	4
8 Through-seat leakage (low test pressure) after cool-down	4
9 External leakage (low test pressure) after cool-down	4
10 Operability	4
11 External leakage in fully open position	4
<b>Appendices</b>	
A Fire test method	6
B Qualification of valves by representative size and pressure rating	11
C Additional information to be included in the test report	13
<b>Tables</b>	
1 Test pressures for PN and Class rated valves	8
2 Other valves qualified according to size	12
3 Other valves qualified by PN rating	13
4 Other valves qualified by Class rating	13
<b>Figures</b>	
1 Recommended systems for fire type-testing of valves (schematic)	6
2 Calorimeter cube design and dimensions	7
3 Location of calorimeter cubes and flame environment thermocouples for DN 150 (NPS 6) and smaller size valves	9
4 Location of calorimeter cubes and flame environment thermocouples for valves larger than DN 150 (NPS 6)	9

BS 6755 : Part 2 : 1987  
Specification. Section one

## Section one. General

### 1 Scope

This Part of BS 6755 specifies fire type-testing requirements and describes, in appendix A, the fire type-test method for confirming the pressure-containing capability of a valve under pressure during and after the fire test\*.

Where requirements in a valve product standard differ from those given in this standard, then the requirements of the product standard apply.

NOTE. The titles of the publications referred to in this standard are listed on the inside back cover.

### 2 Definitions

For the purposes of this Part of BS 6755 the following definitions apply.

**2.1 test pressure.** The internal pressure to which the valve under test is subjected.

**2.2 nominal size (DN).** A numerical designation of size which is common to all components in a piping system other than components designated by outside diameters or by thread size. It is a convenient round number for reference purposes and is only loosely related to manufacturing dimensions.

NOTE 1. Nominal size is designated by the letters DN followed by the appropriate reference number.

NOTE 2. This definition is identical to that given in ISO 6708.

**2.3 nominal pressure (PN).** A numerical designation which is a convenient rounded number for reference purposes.

All equipment of the same nominal size (DN) designated by the same PN number shall have compatible mating dimensions.

NOTE 1. The maximum allowable working pressure depends on materials, design and working temperatures, and should be selected

from the tables of pressure/temperature ratings given in the appropriate standards.

NOTE 2. Nominal pressure is designated by the letters PN followed by the appropriate reference number.

NOTE 3. This definition is identical to that given in ISO 7268.

**2.4 nominal pipe size (NPS).** A designation, in inches, of size which is common to all components in a piping system other than those components designated by outside diameter. It is a convenient round number for reference purposes and is normally only loosely related to manufacturing dimensions.

NOTE 1. Nominal pipe size is designated by the letters NPS followed by a number.

NOTE 2. NPS is used only in association with the Class rating system.

**2.5 Class rating.** A numerical designation for reference purposes.

NOTE 1. The maximum allowable working pressure for a Class rating depends on materials, design and design temperature and should be selected from the tables of pressure/temperature ratings given in the appropriate standards.

NOTE 2. Class rating is designated by the word Class followed by the appropriate reference number.

**2.6 symmetric valve.** A valve having an identical internal construction either side of the centre line of the obturator along the axis running through the body ends.

**2.7 asymmetric valve.** A valve having a non-identical internal construction either side of the centre line of the obturator along the axis running through the body ends.



\*For the purposes of this Part of BS 6755 the terms 'fire type-test' and 'fire test' are synonymous.

## Section two. Conditions of test

### 3 Direction and conditions for valves to be tested

**3.1** Symmetric valves intended for bi-directional installation shall be tested in one direction only.

Asymmetric valves intended for bi-directional installation shall be tested by carrying out the test procedure twice, once in each direction of the potential installation.

NOTE. The same valve may be refurbished and retested or another, identical valve may be tested in the other direction.

Valves intended solely for uni-directional installation are marked accordingly and shall be tested in the direction of recommended installation.

**3.2** If the valve being tested is normally fitted with a gearbox, then the valve shall be tested with the gearbox.

NOTE. In those cases where a valve can be supplied either fitted with or without a gearbox, testing with a gearbox fitted will qualify valves without a gearbox but not vice versa.

**3.3** Valves and gearboxes shall not be protected with insulation material of any form during testing, except where such protection is part of the design of the component(s).

### 4 Pressure relief provision

If the valve under test incorporates a pressure relief device as part of its design and if this device activates during the fire test, then the test shall be continued and any leakage through the device shall be deemed to count as external leakage (see A.5.9 and A.5.10).

The test shall be stopped if the system pressure relief device described in A.2.2.8 activates.

BS 6755 : Part 2 : 1987  
Section three

## Section three. Performance

### 5 General

Valves shall be tested in accordance with appendix A and shall comply with clauses 6 to 11.

### 6 Through-seat leakage (high test pressure) during burn period

The average through-seat leakage at the high test pressure during the burn period (see A.5.9) shall not exceed 400 mL/in/min\*.

NOTE. Through-seat leakage does not include leakage from the bonnet or stem seal.

### 7 External leakage (high test pressure) during burn and cool-down periods

The average external leakage, not including through-seat leakage, of the valve in the closed position at the high test pressure during the burn period and the cool-down period (see A.5.9 and A.5.10, respectively) shall not exceed 100 mL/in/min.

NOTE. External leakage does not include potential leakage from the pipework-to-valve end connection (see note 2 to A.2.1).

### 8 Through-seat leakage (low test pressure) after cool-down

The average through-seat leakage at the low test pressure after the cool-down period (see A.5.11) shall not exceed 40 mL/in/min.

NOTE. Through-seat leakage does not include leakage from the bonnet or stem seal.

### 9 External leakage (low test pressure) after cool-down

The average external leakage, not including through-seat leakage, of the valve in the closed position at the low test pressure after the cool-down period (see A.5.11) shall not exceed 20 mL/in/min.

NOTE. External leakage does not include potential leakage from the pipework-to-valve end connection (see note 2 to A.2.1).

### 10 Operability

After the fire test, the valve shall be unseated from the closed position against the high test pressure differential given in A.5.4 and moved to the fully open position one time (see A.5.13).

### 11 External leakage in fully open position

The average external leakage of the valve in the fully open position at the high test pressure (see A.5.14) shall not exceed 200 mL/in/min.

NOTE. External leakage does not include potential leakage from the pipework-to-valve end connection (see note 2 to A.2.1).

\*The rates are expressed in millilitres per inch of the nominal valve size per minute for Class rated valves and for PN rated valves to maintain strict comparability with the API specifications (see foreword). The equivalent rates can be calculated using data from table 2, which gives the equivalent sizes of PN and Class rated valves for nominal size (DN) against nominal pipe size (NPS). For PN rated valves of nominal size DN 450 and greater, the equivalent sizes may be calculated using the equation:

$$x \times 0.04 = y$$

where

x is the nominal size (DN) of a PN rated valve;

y is the nominal pipe size (NPS) of an equivalent Class rated valve.

## Appendices

### Appendix A. Fire test method

**Warning.** Fire testing of valves is potentially *very hazardous* and it is essential that the safety of personnel is given prime consideration. Because of the possible design of the test valve and test equipment and the nature of the fire test, the potential exists for a hazardous rupture of the pressure boundary components. The use of adequate shields in the area of the test enclosure and other means for the protection of test personnel is necessary. Attention is drawn to the Health and Safety at Work etc. Act 1974.

#### A.1 Principle

The fire test exposes a valve in the closed position, filled with water under pressure, to flames with an environmental temperature in the region of the valve of 760 °C to 980 °C for a period of 30 min and establishes the leakage through the valve and to atmosphere during this period. After cool-down from the fire test the valve is hydrostatically tested to assess the pressure-containing capability of the valve shell and valve seats.

#### A.2 Apparatus

##### A.2.1 General

The test equipment shall be such that it does not subject the valve to externally applied stress affecting the results of the test.

NOTE 1. Schematic diagrams of recommended systems for fire type-testing of valves are given in figure 1.

NOTE 2. Potential pipework-to-valve end connection joint leakage is not evaluated as part of the test and is not included in the allowable external leakage (see clauses 7, 9 and 11). For the purposes of this test, it may be necessary to modify these joints to eliminate leakage.

The equipment shall be designed so that if pipework immediately upstream of the test valve is larger than 25 mm nominal size or larger than one half of the test valve nominal size, the pipework shall be enveloped in flame for a distance of at least 150 mm from the test valve. Downstream of the test valve the pipework shall be between 15 mm and 25 mm nominal size and at such a position as to allow any fluid in the bore of the valve to flow out, thus avoiding entrapment of the fluid.

The enclosure containing the valve shall provide a horizontal clearance between any part of the test valve and the enclosure of a minimum of 150 mm and the minimum height of the enclosure above the top of the test valve shall be 150 mm.

##### A.2.2 Specific apparatus

NOTE. Suitable apparatus is listed in figure 1.

**A.2.2.1** *A vapour trap*, to minimize the cooling effect of the upstream liquid.

**A.2.2.2** *Industrial pressure gauges*, complying with Class 2 of BS 1780 : Part 2 and having a full scale reading of not more than four times and not less than one and a half times the test pressure.

NOTE. Guidance on measurement and calibration systems can be found in BS 5781 : Parts 1 and 2.

**A.2.2.3** *Calorimeter cubes*, made of carbon steel of the design and having the dimensions shown in figure 2 with thermocouple located in the centre of each cube.

**A.2.2.4** *Flame environment temperature thermocouples*.

**A.2.2.5** *Containers*, of a size suitable for collecting the water leaked through and out of the valve under test.

**A.2.2.6** *Calibrated sight gauge*, for measuring the water used.

**A.2.2.7** *Calibrated device*, for measuring the water collected.

**A.2.2.8** *Pressure relief provision*, consisting of a system pressure relief valve to the atmosphere for the test valve centre cavity to protect against potential rupture of the valve if the valve is designed so that liquid can be trapped in the cavity.

The system pressure relief valve setting shall be either:

(a) that determined by the valve manufacturer from data obtained by hydrostatic pressure testing of valves of the same size and type as the fire tested valve; or

(b) when pressure test data are not available, a setting during the burn period, not greater than 1.5 x maximum permissible working pressure at 20 °C.

BS 6755 : Part 2 : 1987  
Appendix A

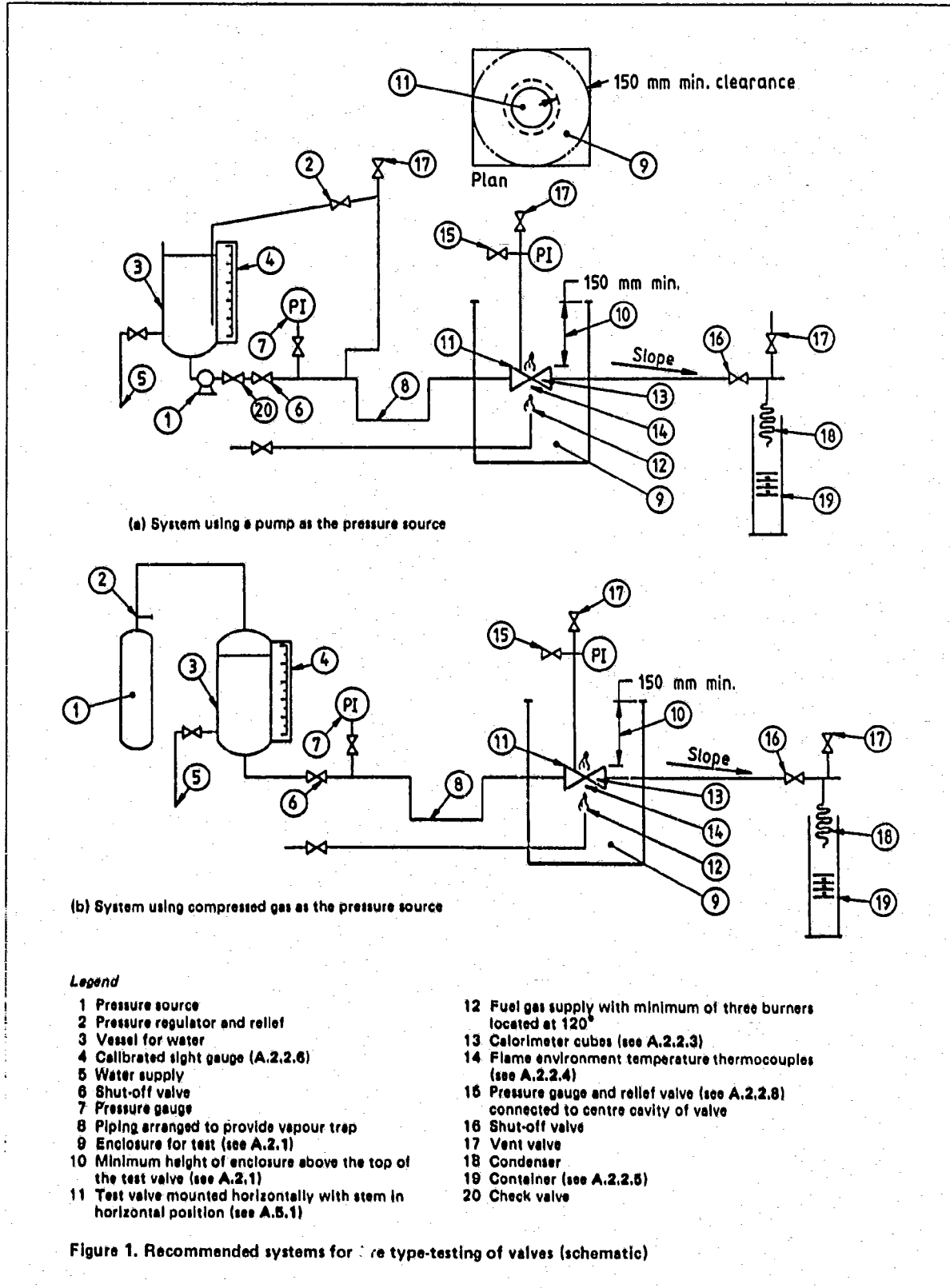

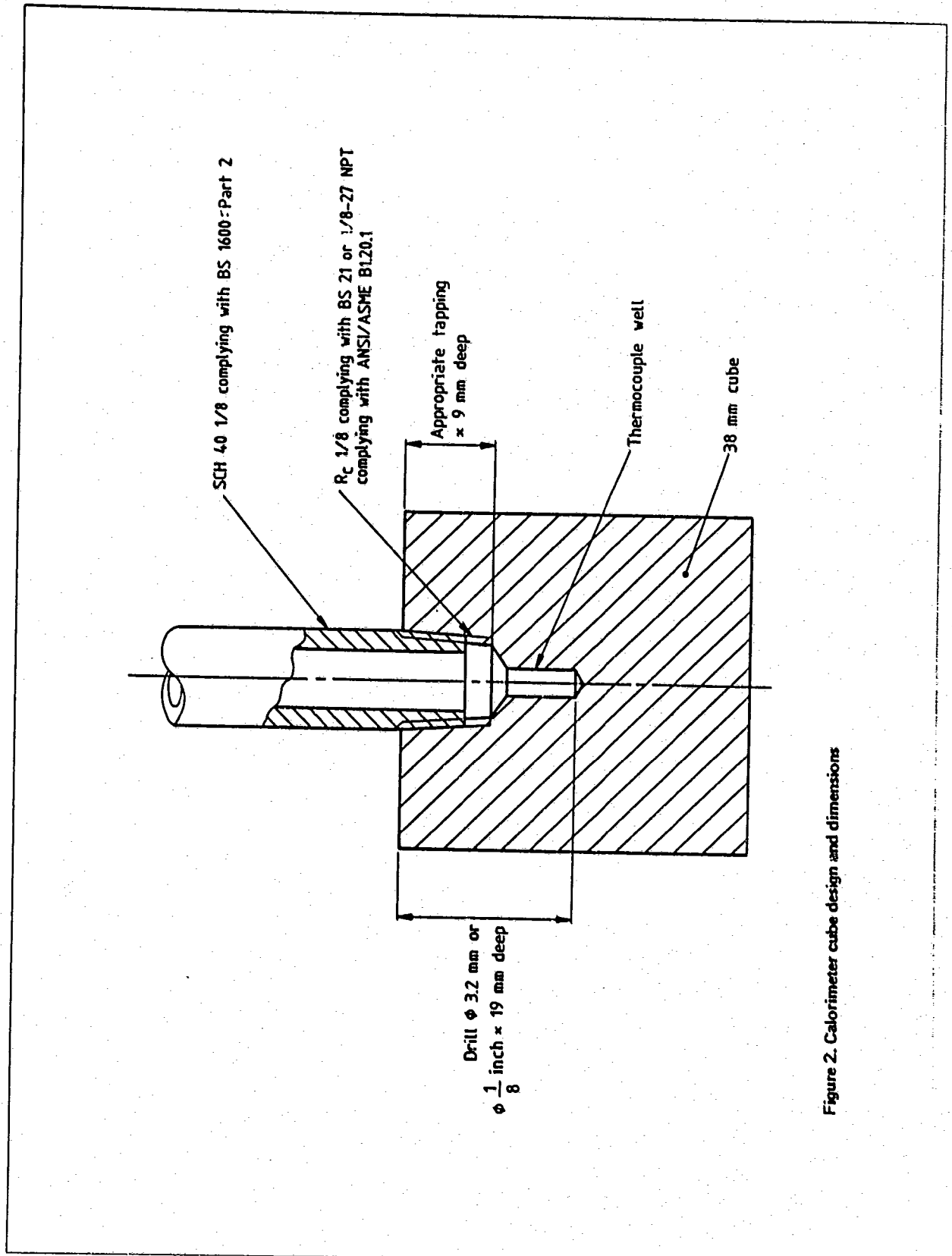

Figure 2. Calorimeter cube design and dimensions

BS 6755 : Part 2 : 1987  
Appendix A**A.3 Test fluid**

The test fluid used shall be water.

**A.4 Test fuel**

The test fuel shall be gaseous.

**A.5 Procedure**

NOTE 1. The numbered items in parentheses refer to the apparatus listed in figure 1.

**A.5.1** Mount valves other than check valves in the test apparatus so that the stem and bore of the valve are in the horizontal position. Mount check valves in their normal operating position.

Locate the flame environment thermocouples (item 14) and calorimeter cubes (item 13) in the positions shown in figures 3 and 4, as appropriate. For valves of nominal size DN 150 (NPS 6) and smaller, two calorimeter cubes shall be used as shown in figure 3. For larger size valves three calorimeter cubes shall be used as shown in figure 4.

**A.5.2** With the test valve in the partially open position, open the water supply valve (item 5), the shut-off valve (item 6), the vent valves (item 17) and the shut-off valve (item 16) to flood the system and purge the air. When the system is filled with water, close the shut-off valve (item 16), the vent valves (item 17) and the water supply valve (item 5).

**1** Pressurize the system with water to a test pressure of 1.5 times the maximum permissible working pressure at 20 °C\*. Check for leaks in the test apparatus. Eliminate leaks as necessary. Without re-introducing air into the system, release the applied pressure and close the test valve and open the shut-off valve (item 16).

**1** **A.5.3** If the valve under test is of the upstream sealing type, determine the volume of water that is trapped between the upstream seat seal and the downstream seat seal, when the valve is closed. Record this volume.

NOTE. It is assumed that during the fire type-test this volume of water would flow through the valve and pass through the downstream seat seal and be collected in the container (item 19). Since this volume has not actually leaked through the upstream seat seal, it is deducted from the total volume collected in the downstream container when determining the through-seat leakage (see A.5.9).

**A.5.4** Pressurize the system to the appropriate high test pressure as follows:

(a) for valves having PN or Class ratings: as given in table 1;

(b) for valves having de-rated seats (i.e. having 20 °C seat pressure retaining capability lower than that of the body in which they are housed) : 75 % of their maximum permissible seat working pressure at 20 °C;

(c) for other valves : 75% of their maximum permissible working pressure at 20 °C.

**2** This test pressure shall be maintained during the burn and cool-down periods, though a once only momentary pressure loss of up to 50 % of the test pressure is permissible provided that the pressure recovers within 2 min.

\* The actual test pressure may be rounded to the next higher 1 bar increment.

Table 1. Test pressures for PN and Class rated valves

PN rating	Class rating	High test pressure*		Low test pressure*	
		bar†	psi	bar†	psi
16	—	12.0	174	2.0	29
—	150	14.5	210	2.0	29
25	—	18.75	272	2.0	29
40	—	30.0	435	2.8	42
—	300	37.2	540	3.5	50
—	400	49.6	720	4.8	70
—	600	74.5	1080	7.2	105
—	800	103.5	1500	—	—
—	900	111.7	1620	—	—
—	1500	186.2	2700	—	—
—	2500	317	4600	—	—

\* Tolerances on all test pressures are ± 10 %.  
† 1 bar = 10<sup>5</sup> N/m<sup>2</sup> = 100 kPa.

Record the reading on the calibrated sight gauge (item 4). Empty the container (item 19).

Adjust the test system, excluding the test valve, during the test period to maintain the temperatures and pressures required.

**A.5.5** Open the fuel supply, establish a fire and monitor the flame environment temperature throughout the burn period of 30 min. Check that the average temperature of the two flame environment thermocouples (item 14) reaches 760 °C within 2 min from the start of the burn period, i.e. from ignition of the burners. Maintain the average temperature between 760 °C to 980 °C with no reading less than 705 °C for the remainder of the burn period of 30 min.

**A.5.6** Check that the average temperature of the calorimeter cubes (item 13) reaches 650 °C within 15 min of starting the burn period. For the remainder of the burn period maintain the calorimeter cubes at a minimum average temperature of 650 °C with no calorimeter cube falling to a temperature of less than 565 °C.

**A.5.7** Record instrument readings (items 7, 13, 14 and 15) every 2 min during the burn period.

NOTE. Thermocouples should be numbered and individual records of temperature should be recorded.

**A.5.8** At the end of the burn period (30 min) shut off the fuel supply.

**A.5.9** Immediately determine the amount of water collected in the container (item 19) and establish the total through-seat leakage during the burn period. Deduct the volume of water trapped between the upstream seat seal and the downstream seat seal if the test valve is an upstream sealing type (see A.5.3).

BS 6755 : Part 2 : 1987  
Appendix A

Continue collecting water in a container (item 19) for use in establishing the external leakage rate of the test valve.

1

Record any leakage through the valve pressure relief device, if fitted, as external leakage.

**A.5.10** Either force cool the valve, or allow the valve to cool naturally to 100 °C or less. Record the time taken to cool the external surface of the valve to 100 °C.

**WARNING 1.** For safety considerations, the manufacturer's advice should be sought when seeking to force cool a valve from high temperatures.

Record the reading on the sight gauge (item 4) and determine the quantity of water in the container (item 19) when the external surface of the valve has cooled to 100 °C.

Record the external leakage. Record any leakage through the valve pressure relief device, if fitted, as external leakage.

Allow the internal parts of the valve to cool to below 100 °C before proceeding to A.5.11 to A.5.14.

**WARNING 2.** The internal parts of the valve could remain at significantly higher temperatures than the external surface of the valve and the temperatures between internal parts and external surfaces should be allowed to equalize as far as practicable.

**NOTE.** If practicable, thermocouples may be used to determine the temperature of internal parts. Otherwise, with advice from the valve manufacturer as necessary, sufficient time should be allowed for the internal parts to cool to below 100 °C.

**A.5.11** For valves with a maximum permissible working pressure at 20 °C of 110 bar or lower, decrease the hydrostatic pressure to the appropriate low test pressure as follows:

(a) for valves having PN or Class ratings: as given in table 1;

(b) for valves having de-rated seats: 7% of the maximum permissible seat working pressure at 20 °C or 2 bar whichever is the greater;

(c) for other valves: 7% of the maximum permissible working pressure at 20 °C or 2 bar whichever is the greater.

Measure the through-seat and external leakage over a 5 min period.

**A.5.12** For valves with a maximum working pressure at 20 °C of over 110 bar, maintain the hydrostatic pressure at the appropriate high test pressure given in A.5.4. For valves with a maximum working pressure at 20 °C of 110 bar or lower (see A.5.11) increase the pressure in the test valve to the appropriate high test pressure given in A.5.4.

**A.5.13** Fully open the test valve against the high test pressure differential using the applicable mode of operation and close the shut-off valve (item 16). Record the maximum force required to operate the valve. Vent the pipework and valve body cavity.

**A.5.14** Measure and record external leakage for a period of 5 min after the valve is in the fully open position (or, for double seated valves, the partially open position) at the appropriate high test pressure (see A.5.4).

## A.6 Calculations

Calculate the average leakage rates as required for clauses 6, 7, 8, 9 and 11.

## A.7 Test report

The test report shall include the following information:

- (a) a statement confirming that a valve representative of the type and size supplied has been tested in accordance with this Part of BS 6755 and as required by the product standard, if applicable;
- (b) the number of the product standard, if applicable;
- (c) whether a gear box is fitted to the test valve or not and, if fitted, the type of box, manufacturer's name, model number and mechanical advantage;
- (d) the size and the PN or Class rating of the test valve;
- (e) time of test start, i.e. ignition of burners;
- (f) temperature recorded at start and at 2 min intervals throughout duration of test (see A.5.7) with individual records for each thermocouple;
- (g) through-seat leakage (high pressure test) during burn period (see clause 6);
- (h) external leakage (high pressure test) during burn and cool-down periods (see clause 7);
- (i) time required for valve to cool down to 100 °C (see A.5.10) and if the valve was allowed to cool naturally or force cooled;
- (j) through-seat leakage (low test pressure) after cool-down (see clause 8);
- (k) external leakage (low test pressure) after cool-down (see clause 9);
- (l) whether the test valve unseated and moved to the fully open position (see clause 10) and the maximum force required to unseat and operate the valve and the method used to measure the force (see A.5.13);
- (m) external leakage in fully open position (see clause 11);
- (n) if the valve is asymmetric and intended for bi-directional installation, the test results in both directions;
- (o) observations made during the course of the test that may have a bearing on the results provided;
- (p) whether the test valve complied, or not, with the requirements of this Part of BS 6755 and with those of the product standard, if applicable.

**NOTE 1.** The purchaser of a valve to a fire tested design should specify that a test report, giving details of the fire type-test, is to be provided on the enquiry and/or order for that valve.

**NOTE 2.** A witnessing authority may be designated to officiate at the fire type-test of a valve. A test report should be prepared either by the test house carrying out the test or by the witnessing authority. If prepared by the test house, the report should be endorsed by any witnessing authority.

**NOTE 3.** Guidance on additional information which should be included in the test report is given in appendix C.

2

2

2

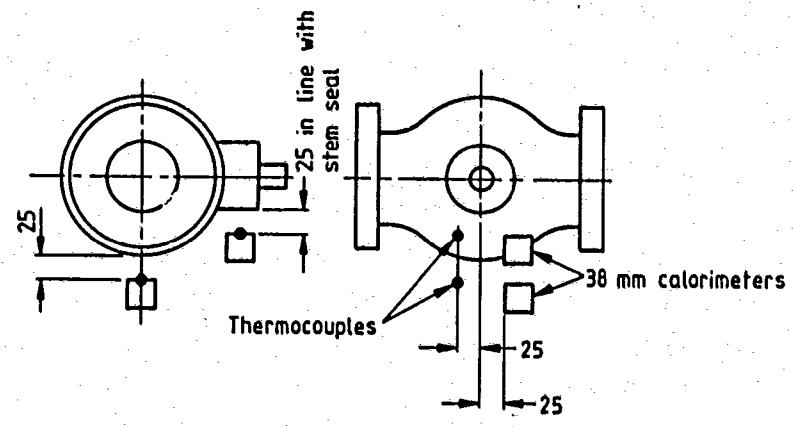

All dimensions are in millimetres.

Figure 3. Location of calorimeter cubes and flame environment thermocouples for DN 150 (NPS 6) and smaller size valves (see A.5.1)

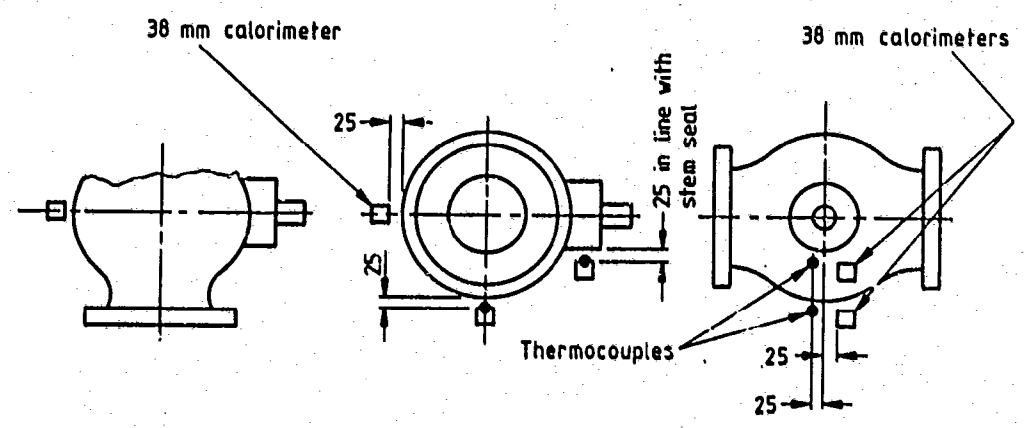

All dimensions are in millimetres.

Figure 4. Location of calorimeter cubes and flame environment thermocouples for valves larger than DN 150 (NPS 6) (see A.5.1)

## Appendix B. Qualification of valves by representative size and pressure rating

### B.1 General

Instead of testing each size and nominal pressure or Class rating of a given valve design, other valves of both the same design and the same non-metallic materials as the test valve with respect to the seat-to-closure member seal, seat-to-body seal, stem seal and body joint and seal, is deemed to have been fire tested subject to the following limitations.

- (a) A test valve can be used to qualify valves larger than the test valve but not exceeding twice the nominal size of the test valve (see B.2). A size DN 400 (NPS16) valve qualifies all larger sizes.
- (b) A test valve can be used to qualify valves with higher PN or Class ratings but not exceeding twice the PN or Class rating of the test valve, except where otherwise indicated in tables 3 and 4 (see B.3).
- (c) A reduced bore (or venturi pattern) valve can be used to qualify a smaller nominal size, full bore (or regular pattern) valve when the components associated with the obturator, seats, seals and stem are identical in design and size. In such a case the permissible average leakage rates are those applicable to the full bore (or regular pattern) valve.

#### Example 1

A DN60/PN16 test valve can be used to qualify the following valves:

DN60/PN16, DN65/PN16, DN80/PN16,  
DN100/PN16, DN65/PN25, DN80/PN25,  
DN100/PN25,

NPS2/Class 150, NPS3/Class 150, NPS4/Class 150,  
NPS2/Class 300, NPS3/Class 300, NPS4/Class 300.

#### Example 2

A NPS4/Class 300 test valve can be used to qualify the following valves:

NPS4/Class 300, NPS6/Class 300,  
NPS8/Class 300, NPS4/Class 400,  
NPS6/Class 400, NPS8/Class 400, NPS4/Class 600,  
NPS6/Class 600, NPS8/Class 600,  
DN100/PN25, DN125/PN25, DN150/PN25,  
DN200/PN25, DN100/PN40, DN125/PN40,  
DN150/PN40, DN200/PN40.

#### Example 3

A DN80/65/PN25 reduced bore (or venturi pattern) test valve can be used to qualify DN65, DN80, DN100, DN 125, NPS 2½, NPS3, NPS4, NPS5 full bore (or regular pattern) valves.

NOTE 1. For the purpose of this clause, the nominal size of Class rated valves is determined by the size of the end connections.

NOTE 2. The types of valve body ends are not considered by this standard, however, the mass of the valve is determined in part by the body end type. So far as qualification to this standard is concerned and providing that all other qualification criteria have been met, valves with ends different from the test valve will also qualify provided that:

- (a) their mass is greater than that of the test valve; or
- (b) their mass is not less than 90 % of that of the test valve.

NOTE 3. In operating product compliance certification systems, separate type approval testing of valves of the same basic design as the test valve, but made using different metals, might be required to verify that the fire tested performance was not impaired by such material change.

### B.2 Qualification of valves by size

The valves of other nominal sizes deemed to have been fire type-tested relative to the actual valve tested are given in table 2.

PN rated valves qualify Class rated and threaded end valves and vice versa for the sizes given.

BS 6755 : Part 2 : 1987  
Appendix B

Table 2. Other valves qualified according to size			
PN rated valves, excluding threaded end valves		Class rated and threaded end valves	
Size of valve tested	Other valve sizes qualified	Size of valve tested	Other valve sizes qualified
DN	DN	NPS	NPS
8	8, 10, 15	1/4	1/4, 3/8, 1/2
10	10, 15, 20	3/8	3/8, 1/2, 3/4
15	15, 20, 25	1/2	1/2, 3/4, 1
20	20, 25, 32, 40	3/4	3/4, 1, 1 1/4, 1 1/2
25	25, 32, 40, 50	1	1, 1 1/4, 1 1/2, 2
32	32, 40, 50, 65	1 1/4	1 1/4, 1 1/2, 2, 2 1/2
40	40, 50, 65, 80	1 1/2	1 1/2, 2, 2 1/2, 3
50	50, 65, 80, 100	2	2, 2 1/2, 3, 4
65	65, 80, 100, 125	2 1/2	2 1/2, 3, 4, 5
80	80, 100, 125, 150	3	3, 4, 5, 6
100	100, 125, 150, 200	4	4, 5, 6, 8
125	125, 150, 200, 250	5	5, 6, 8, 10
150	150, 200, 250, 300	6	6, 8, 10, 12
200	200, 250, 300, 350, 400	8	8, 10, 12, 14, 16
250	250, 300, 350, 400, 450, 500	10	10, 12, 14, 16, 18, 20
300	300, 350, 400, 450, 500, 600	12	12, 14, 16, 18, 20, 24
350	350, 400, 450, 500, 600, 700	14	14, 16, 18, 20, 24, 28
400	400 and larger	16	16 and larger

### B.3 Qualification of valves by pressure rating

The valves of other PN or Class ratings deemed to have been fire type-tested relative to the actual valve tested are given in tables 3 and 4.

Table 3. Other valves qualified by PN rating		
PN rating of valve tested	Other valves qualified:	
	PN rating	Class rating
16	16, 25	150, 300
25	25, 40	300, 400, 600
40	40	300, 400, 600

Table 4. Other valves qualified by Class rating		
Class rating of valve tested	Other valves qualified	
	Class rating	PN rating
150	150, 300	16, 25, 40
300	300, 400, 600	25, 40
400	400, 600, 800	—
600	600, 800, 900	—
800	800, 900, 1500	—
900	900, 1500	—
1500	1500, 2500	—
2500	2500	—

### Appendix C. Additional information to be included in the test report

The following additional information should be included in the test report:

- (a) date of fire type-test;
- (b) place at which the fire type-test was conducted;
- (c) specification used for the fire type-test (including issue date of publication and applicable amendments);
- (d) type of valve tested, e.g. ball, gate, butterfly, etc.;
- (e) manufacturer's name and address;
- (f) statement to confirm that the valve to be fire tested has passed all the required hydrostatic and air type and production pressure tests required by the standard to which the valve was manufactured (manufacturer's statement may be accepted);
- (g) full description of the valve tested, including nominal size, mass, if reduced or full bore, rating, material for body/bonnet, trim material and the manufacturer's reference identifying number;
- (h) markings on the valve listed and their locations identified, including manufacturer's nameplate data (if fitted);
- (i) a manufacturer's sectional drawing of the valve and a detailed parts list of all the valve components tested, identified in the text by reference number (drawing number) and the revision and date of issue of the documents;
- (j) results of visual examination of the valve after testing to confirm whether the design of the valve components complies with the drawing and parts list supplied by the manufacturer;
- (k) a statement as to whether the valve was selected by the witnessing authority at random or presented for test by the manufacturer without choice;
- (l) indication on the cover sheet or index sheet of the report of the total number of pages contained in the document (including drawings) each page being numbered, e.g. page 1 of 12, 2 of 12, etc.

#### Publications referred to

- BS 21 Specification for pipe threads for tubes and fittings where pressure-tight joints are made on the threads (metric dimensions)
- BS 1600 Specification for dimensions of steel pipe for the petroleum industry  
Part 2 Metric units
- BS 1780 Specification for bourdon tube pressure and vacuum gauges  
Part 2 Metric units
- \*BS 5146 Inspection and test of valves  
Part 1 Specification for steel valves for the petroleum, petrochemical and allied industries
- BS 5781 Measurement and calibration systems  
Part 1 Specification for system requirements  
Part 2 Guide to the use of BS 5781 : Part 1 'Specification for system requirements'
- ISO 6708 Pipe components — Definition of nominal size
- ISO 7268 Pipe components — Definition of nominal pressure

\*†API Specification 6D Pipeline valves, end closures, connectors and swivels

\*†API Specification 6FA Fire test for valves

\*†API Standard 607 Fire test for soft-seated quarter-turn valves

†ANSI/ASME B1.20.1 Pipe threads, general purpose (inch)

\*Referred to in the foreword only.

†Available from BSI Sales Department, Linford Wood, Milton Keynes MK14 6LE.

# BS 6755 : Part 2 : 1987

This British Standard, having been approved under the direction of the Piping Systems Components Standards Committee, was published under the authority of the Board of BSI and comes into effect on 31 July 1987.

© British Standards Institution, 1987  
 ISBN 0 580 16081 0

The following BSI references relate to the work on this standard:  
 Committee reference PSE/7 Draft for comment 86/73183 DC

British Standards Institution, Incorporated by Royal Charter, BSI is the independent national body for the preparation of British Standards. It is the UK member of the International Organization for Standardization and UK sponsor of the British National Committee of the International Electrotechnical Commission.

In addition to the preparation and promulgation of standards, BSI offers specialist services including the provision of information through the BSI Library and Standardline Database; Technical Help to Exporters; and other services. Advice can be obtained from the Enquiry Section, BSI, Milton Keynes MK14 6LE, telephone 0908 221166, telex 825777.

Copyright. Users of British Standards are reminded that copyright subsists in all BSI publications. No part of this publication may be reproduced in any form without the prior permission in writing of BSI. This does not preclude the free use, in the course of

implementing the standard, of necessary details such as symbols and size, type or grade designations. Enquiries should be addressed to the Publications Manager, BSI, Linford Wood, Milton Keynes MK14 6LE. The number for telephone enquiries is 0908 220022 and for telex 825777.

Contract requirements. A British Standard does not purport to include all the necessary provisions of a contract. Users of British Standards are responsible for their correct application.

Revision of British Standards. British Standards are revised, when necessary, by the issue either of amendments or of revised editions. It is important that users of British Standards should ascertain that they are in possession of the latest amendments or editions.

Automatic updating service. BSI provides an economic, individual and automatic standards updating service called PLUS. Details are available from BSI Enquiry Section at Milton Keynes, telephone 0908 221166, telex 825777.

Information on all BSI publications is in the *BSI Catalogue*, supplemented each month by *BSI News* which is available to subscribing members of BSI and gives details of new publications, revisions, amendments and withdrawn standards. Any person who, when making use of a British Standard, encounters an inaccuracy or ambiguity, is requested to notify BSI without delay in order that the matter may be investigated and appropriate action taken.

## Committees responsible for this British Standard

The preparation of this British Standard was entrusted by the Piping Systems Components Standards Committee (PSE/-) to Technical Committee PSE/7, upon which the following bodies were represented:

- Amalgamated Union of Engineering Workers
- Associated Offices Technical Committee
- Association of Bronze and Brass Founders
- British Chemical Engineering Contractors' Association
- British Compressed Gases Association
- British Fluid Power Association
- British Foundry Association
- British Gas plc
- British Maritime Technology
- British Shipbuilders
- British Valve Manufacturers' Association Ltd.
- Copper Development Association

- Copper Tube Fittings Manufacturers' Association Ltd.
- Electricity Supply Industry in England and Wales
- Energy Industries Council
- Engineering Equipment and Materials Users' Association
- GAMBICA (BEAMA Ltd.)
- General Council of British Shipping
- Health and Safety Executive
- Institute of British Foundrymen
- Institution of Chemical Engineers
- Institution of Gas Engineers
- Institution of Mechanical Engineers
- Institution of Water Engineers and Scientists
- Society of British Gas Industries
- Steel Casting Research and Trade Association
- Water Authorities Association
- Water Companies Association

## Amendments issued since publication

Amd. No.	Date of issue	Text affected

British Standards Institution · 2 Park Street London W1A 2BS · Telephone 01-629 9000 · Telex 266933



Amendment No. 1  
published and effective from 30 November 1990  
to BS 6755 Testing of valves  
Part 2 : 1987 Specification for fire  
type-testing requirements

Revised text

AMD 6272  
November 1990

Foreword

After paragraph 6 insert the following new paragraph.  
'Until such time that sufficient experience is gained with this particular fire test it is not possible to make definitive statements regarding qualification of valves of the same basic design as the test valve, but made using different metals (see note 3 to B.1).'

AMD 6272  
November 1990

Clause 2.6 symmetric valve

Delete the existing subclause and substitute the following new subclause.  
'2.6 symmetric valve. A valve having an identical internal construction either side of the centre line of the obturator along the axis running through the body ends.'

AMD 6272  
November 1990

Clause 2.7 asymmetric valve

Delete the existing subclause and substitute the following new subclause.  
'2.7 asymmetric valve. A valve having a non-identical internal construction either side of the centre line of the obturator along the axis running through the body ends.'

AMD 6272  
November 1990

Clause A.5 Procedure

In subclause A.5.2 delete sentence 3 i.e. 'Close the test valve and open the shut-off valve (Item 16)'. Insert a new final sentence, 'Without re-introducing air into the system, release the applied pressure and close the test valve and open the shut-off valve (Item 16).'

In subclause A.5.9 delete sentence 4, i.e. 'Record the external leakage.'

AMD 6272  
November 1990

### Clause B.1 General

Delete the existing clause B.1 and substitute the following new clause.

#### 'B.1 General

Instead of testing each size and nominal pressure or Class rating of a given valve design, other valves of both the same design and the same non-metallic materials as the test valve with respect to the seat-to-closure member seal, seat-to-body seal, stem seal and body joint and seal, is deemed to have been fire tested subject to the following limitations.

(a) A test valve can be used to qualify valves larger than the test valve but not exceeding twice the nominal size of the test valve (see B.2). A size DN 400 (NPS16) valve qualifies all larger sizes.

(b) A test valve can be used to qualify valves with higher PN or Class ratings but not exceeding twice the PN or Class rating of the test valve, except where otherwise indicated in tables 3 and 4 (see B.3).

(c) A reduced bore (or venturi pattern) valve can be used to qualify a smaller nominal size, full bore (or regular pattern) valve when the components associated with the obturator, seats, seals and stem are identical in design and size. In such a case the permissible average leakage rates are those applicable to the full bore (or regular pattern) valve.

##### Example 1

A DN50/PN16 test valve can be used to qualify the following valves:

DN50/PN16, DN65/PN16, DN80/PN16,  
DN100/PN16, DN65/PN25, DN80/PN25,  
DN100/PN25,

NPS2/Class 150, NPS3/Class 150, NPS4/Class 150,  
NPS2/Class 300, NPS3/Class 300, NPS4/Class 300.

##### Example 2

A NPS4/Class 300 test valve can be used to qualify the following valves:

NPS4/Class 300, NPS6/Class 300,  
NPS8/Class 300, NPS4/Class 400,  
NPS6/Class 400, NPS8/Class 400, NPS4/Class 600,  
NPS6/Class 600, NPS8/Class 600,

DN100/PN25, DN125/PN25, DN150/PN25,  
DN200/PN25, DN100/PN40, DN125/PN40,  
DN150/PN40, DN200/PN40.

##### Example 3

A DN80/65/PN25 reduced bore (or venturi pattern) test valve can be used to qualify DN65, DN80, DN100, DN 125, NPS 2½, NPS3, NPS4, NPS5 full bore (or regular pattern) valves.

NOTE 1. For the purpose of this clause, the nominal size of Class rated valves is determined by the size of the end connections.

NOTE 2. The types of valve body ends are not considered by this standard, however, the mass of the valve is determined in part by the body end type. So far as qualification to this standard is concerned and providing that all other qualification criteria have been met, valves with ends different from the test valve will also qualify provided that:

- (a) their mass is greater than that of the test valve; or
- (b) their mass is not less than 90 % of that of the test valve.

NOTE 3. In operating product compliance certification systems, separate type approval testing of valves of the same basic design as the test valve, but made using different metals, might be required to verify that the fire tested performance was not impaired by such material change.



Amendment No. 2  
published and effective from 28 June 1991  
to BS 6755 : Part 2 : 1987

Testing of valves  
Part 2. Specification for fire type-testing  
requirements

### Revised text

AMD 6712  
June 1991

#### Clause A.5.4

Delete item (b) and substitute the following.

'(b) for valves having de-rated seats (i.e. having 20 °C seat pressure retaining capability lower than that of the body in which they are housed) : 75 % of their maximum permissible seat working pressure at 20 °C;

(c) for other valves : 75% of their maximum permissible working pressure at 20 °C.'

AMD 6712  
June 1991

#### Clause A.5.11

Insert the following new text after item (a).

'(b) for valves having de-rated seats : 7% of the maximum permissible seat working pressure at 20 °C or 2 bar whichever is the greater.'

Renumber the existing item (b) as item (c).

AMD 6712  
June 1991

#### Clause A.5.14

Delete the entire clause and substitute the following.

'A.5.14 Measure and record external leakage for a period of 5 min after the valve is in the fully open position (or, for double seated valves, the partially open position) at the appropriate high test pressure (see A.5.4).'