

Bolted Bonnet Steel Gate Valves for Petroleum and Natural Gas Industries

**API Standard 600, Eleventh Edition
October 2001
ISO 10434: 1998
ANSI/API Std 600-2001**



**Helping You
Get The Job
Done Right.SM**



Contents

Important Information Concerning Use of Asbestos or Alternative Materials.....	3
Special Notes	4
API Foreword.....	5
ISO Foreword.....	6
Introduction	7
1 Scope	8
2 Normative references	9
3 Definitions	10
4 Pressure/temperature ratings.....	10
5 Design.....	10
5.1 Body wall thickness.....	10
5.2 Bonnet wall thickness	11
5.3 Body dimensions	12
5.3.1 Flanged ends.....	12
5.3.2 Butt-welding ends.....	14
5.3.3 Body seats.....	15
5.3.4 Openings	16
5.4 Bonnet dimensions.....	16
5.5 Bonnet-to-body joint.....	16
5.6 Gate.....	18
5.7 Yoke	18
5.8 Stem and stem nut.....	19
5.9 Packing and packing box	20
5.10 Bolting.....	21
5.11 Operation.....	21
5.12 Auxiliary connections.....	22
6 Materials	25
6.1 Materials other than trim materials	25
6.2 Trim.....	25
6.3 Repair.....	28
7 Testing, inspection and examination	28
7.1 Pressure tests	28
7.1.1 Shell test.....	28
7.1.2 Closure tightness test	29
7.1.3 Backseat test.....	30
7.1.4 Optional closure tightness test	30
7.2 Inspection	31
7.2.1 At the valve manufacturer’s factory	31
7.2.2 Other than at the valve manufacturer’s factory	31
7.2.3 Extent of inspection.....	31
7.3 Examination.....	31
7.4 Supplementary examination	31
8 Marking	31
8.1 Legibility	31

8.2 Body markings 32
8.3 Ring joint markings..... 32
8.4 Identification plate marking 32
9 Preparation for despatch..... 33
Annex A (informative) Information to be specified by the purchaser34
Annex B (informative) Identification of valves terms 35
Annex C (informative) Modifications to ISO 10434 36

Important Information Concerning Use of Asbestos or Alternative Materials

Asbestos is specified or referenced for certain components of the equipment described in some API standards. It has been of extreme usefulness in minimizing fire hazards associated with petroleum processing. It has also been a universal sealing material, compatible with most refining fluid services.

Certain serious adverse health effects are associated with asbestos, among them the serious and often fatal diseases of lung cancer, asbestosis, and mesothelioma (a cancer of the chest and abdominal linings). The degree of exposure to asbestos varies with the product and the work practices involved.

Consult the most recent edition of the Occupational Safety and Health Administration (OSHA), U.S. Department of Labor, Occupational Safety and Health Standard for Asbestos, Tremolite, Anthophyllite, and Actinolite, 29 *Code of Federal Regulations*, Section 1910.1001; the U.S. Environmental Protection Agency, National Emission Standard for Asbestos, 40 *Code of Federal Regulations*, Sections 61.140 through 61.156; and the U.S. Environmental Protection Agency (EPA) rule on labeling requirements and phased banning of asbestos products (Sections 763.160-179).

There are currently in use and under development a number of substitute materials to replace asbestos in certain applications. Manufacturers and users are encouraged to develop and use effective substitute materials that can meet the specifications for, and operating requirements of, the equipment to which they would apply.

SAFETY AND HEALTH INFORMATION WITH RESPECT TO PARTICULAR PRODUCTS OR MATERIALS CAN BE OBTAINED FROM THE EMPLOYER, THE MANUFACTURER OR SUPPLIER OF THAT PRODUCT OR MATERIAL, OR THE MATERIAL SAFETY DATA SHEET.

Special Notes

API publications necessarily address problems of a general nature. With respect to particular circumstances, local, state, and federal laws and regulations should be reviewed.

API is not undertaking to meet the duties of employers, manufacturers, or suppliers to warn and properly train and equip their employees, and others exposed, concerning health and safety risks and precautions, nor undertaking their obligations under local, state, or federal laws.

Information concerning safety and health risks and proper precautions with respect to particular materials and conditions should be obtained from the employer, the manufacturer or supplier of that material, or the material safety data sheet.

Nothing contained in any API publication is to be construed as granting any right, by implication or otherwise, for the manufacture, sale, or use of any method, apparatus, or product covered by letters patent. Neither should anything contained in the publication be construed as insuring anyone against liability for infringement of letters patent.

Generally, API standards are reviewed and revised, reaffirmed, or withdrawn at least every five years. Sometimes a one-time extension of up to two years will be added to this review cycle. This publication will no longer be in effect five years after its publication date as an operative API standard or, where an extension has been granted, upon republication. Status of the publication can be ascertained from the standardization manager [telephone (202) 682-8000]. A catalog of API publications and materials is published annually and updated quarterly by API, 1220 L Street, N.W., Washington, D.C. 20005.

This document was produced under API standardization procedures that ensure appropriate notification and participation in the developmental process and is designated as an API standard. Questions concerning the interpretation of the content of this standard or comments and questions concerning the procedures under which this standard was developed should be directed in writing to the standardization manager, American Petroleum Institute, 1220 L Street, N.W., Washington, D.C. 20005. Requests for permission to reproduce or translate all or any part of the material published herein should also be addressed to the director.

API standards are published to facilitate the broad availability of proven, sound engineering and operating practices. These standards are not intended to obviate the need for applying sound engineering judgment regarding when and where these standards should be utilized. The formulation and publication of API standards is not intended in any way to inhibit anyone from using any other practices.

Any manufacturer marking equipment or materials in conformance with the marking requirements of an API standard is solely responsible for complying with all the applicable requirements of that standard. API does not represent, warrant, or guarantee that such products do in fact conform to the applicable API standard.

API Foreword

This standard is under the jurisdiction of the API CRE Subcommittee on Piping. This API standard is a modified adoption of the English version of ISO 10434: 1998. ISO 10434 was prepared by Technical Committee ISO/TC 153, Valves, SC1, Design, manufacture, marking and testing and ISO/TC67, materials, equipment and offshore structures for petroleum and natural gas industries, SC6, processing equipment and systems.

In this standard, certain modifications have been made. These technical deviations have been incorporated. A complete list of modifications is given in API Standard Annex C.

For the purposes of this standard, the following editorial changes have been made:

Addition of API Special Notes, API Foreword, and Important information Concerning Use of Asbestos or Alternate Materials

This standard shall become effective on the date printed on the cover but may be used voluntarily from the date of publication.

API publications may be used by anyone desiring to do so. Every effort has been made by the Institute to assure the accuracy and reliability of the data contained in them; however, the Institute makes no representation, warranty, or guarantee in connection with this publication and hereby expressly disclaims any liability or responsibility for loss or damage resulting from its use or for the violation of any federal, state, or municipal regulation with which this publication may conflict.

Suggested revisions are invited and should be submitted to the API Standards Department, American Petroleum Institute, 1220 L Street, N.W., Washington, D.C. 20005.

ISO Foreword

ISO (the International Organization for Standardization) is a worldwide federation of national standards bodies (ISO member bodies). The work of preparing International Standards is normally carried out through ISO technical committees. Each member body interested in a subject for which a technical committee has been established has the right to be represented on that committee. International organizations, governmental and non-governmental, in liaison with ISO, also take part in the work. ISO collaborates closely with the International Electrotechnical Commission (IEC) on all matters of electrotechnical standardization.

International Standards are drafted in accordance with the rules given in the ISO/IEC Directives, Part 3.

Draft International Standards adopted by the technical committees are circulated to the member bodies for voting. Publication as an International Standard requires approval by at least 75% of the member bodies casting a vote.

Attention is drawn to the possibility that some of the elements of this part of ISO 10434 may be the subject of patent rights. ISO shall not be held responsible for identifying any or all such patent rights.

International Standard ISO 10434 was prepared by Technical Committee ISO/TC 153, *Valves*, Subcommittee SC 1, *Design, manufacture, marking and testing*, and ISO/TC 67, *Materials equipment and offshore structures for petroleum and natural gas industries*, Subcommittee SC 6, *Processing equipment and systems*.

Annexes A, B and C of this International Standard are for information only. Annex C contains modifications to ISO 10434: 1998. These modifications have been embedded into this API 600/ISO 10434 version.

Introduction

The purpose of this International Standard is to establish, in ISO format, the basic requirements and practices for flanged and butt-welding end steel gate valves of bolted bonnet construction which parallel those given in American Petroleum Institute Standard API 600, Tenth Edition. In order to maintain compatibility with the flanges defined in ISO 7005-1 and the flanges in the American National Standard ASME B16.5, valves have been designated to be PN-marked for the former and Class-marked for the latter. It is not the purpose of this International Standard to replace ISO 6002 or any other International Standard which is not identified with petroleum refinery or natural gas industry applications. It does, however, supersede API 600, Tenth Edition.

Bolted bonnet steel gate valves for petroleum and natural gas industries

1 Scope

This International Standard specifies the requirements for a heavy duty series of bolted bonnet steel gate valves for petroleum refinery and related applications where corrosion, erosion and other service conditions indicate a need for full port openings, heavy wall sections and extra large stem diameters.

This specification sets forth the requirements for the following gate valve features:

- bolted bonnet;
- outside screw and yoke;
- rising stems;
- non-rising handwheels;
- single or double gate;
- wedge or parallel seating;
- metallic seating surfaces;
- flanged or butt-welding ends.

It covers valves of the nominal sizes DN:

25; 32; 40; 50; 65; 80; 100; 150; 200; 250; 300; 350; 400; 450; 500; 600

and is applicable for pressure designations PN:

20; 50; 110; 150; 260; 420

when metric sized bolt holes are provided in end flanges and PN designations are marked on the valve body.

It also covers valves of the corresponding nominal pipe sizes NPS:

1; 1¹/₄; 1¹/₂; 2; 2¹/₂; 3; 4; 6; 8; 10; 12; 14; 16; 18; 20; 24

and applies for equivalent nominal Class ratings:

150; 300; 600; 900; 1 500; 2 500

when inch-sized bolt holes are provided in end flanges and Class designations are marked on the valve body.

It also covers additional marking requirements for valves that are PN (or Class) designated but have flanges drilled for inch (or metric) bolt holes.

2 Normative references

The following standards contain provisions which, through reference in this text, constitute provisions of this International Standard. At the time of the publication, the editions indicated were valid. All standards are subject to revision, and parties to agreements based on this International Standard are encouraged to investigate the possibility of applying the most recent editions of the standards indicated below. Members of IEC and ISO maintain registers of currently valid International Standards.

ISO 7-1:1994, *Pipe threads where pressure-tight joints are made on the threads — Part 1: Dimensions, tolerances and designation.*

ISO 4200:1991, *Plain end steel tubes, welded and seamless — Dimensions.*

ISO 5208:1993, *Industrial valves — Pressure testing of valves.*

ISO 5209:1977, *General purpose industrial valves — Marking.*

ISO 5210:1991, *Industrial valves — Multi-turn valve actuator attachments.*

ISO 5752:.....¹⁾, *Metal valves for use in flanged pipe systems — Face-to-face and centre-to-face dimensions.*

ISO 6708:1995, *Pipework components — Definition and selection of DN (nominal size).*

ISO 7005-1:1992, *Metallic flanges — Part 1: Steel flanges.*

ISO 7268:1983, *Pipe components — Definition of nominal pressure.*

ASME B1.1:1989, *Unified inch screw threads (UN and UNR thread form).*

ASME B1.5:1988 (R1994), *Acme screw threads.*

ASME B1.8:1988 (R1994), *Stub Acme screw threads.*

ASME B1.12:1987 (R1992), *Screw threads — Class 5 interference — Fit thread.*

ASME B1.20.1:1983 (R1992), *Pipe threads, general purpose (inch).*

ASME B16.5:1996, *Pipe flanges and flanged fittings.*

ASME B16.34:1996, *Valves — Flanged, threaded and welding end.*

ASME B18.2.2:1987 (R1993), *Square and hex nuts (inch series).*

ASTM A193:1996, *Specification for alloy steel and stainless steel bolting materials for high-temperature service.*

ASTM A194:1996, *Specification for carbon and alloy steel nuts for bolts for high-pressure and high-temperature service.*

ASTM A307:1994, *Specification for carbon steel bolts and studs, 60 000 psi tensile strength.*

MSS SP-55:1985 (R1990), *Quality standard for steel castings, visual surface examination.*

1) To be published. (Revision of ISO 5752:1982)

3 Definitions

For the purposes of this International Standard, the definition of nominal size given in ISO 6708 and of nominal pressure given in ISO 7268 apply. Alternatively, the definitions of pressure Class and Nominal Pipe Size given in ANSI/ASME B16.34 apply.

4 Pressure/temperature ratings

4.1 The pressure/temperature ratings applicable to the valves specified in this International Standard shall be in accordance with those specified in the tables of ASME B16.34 for Standard Class for the applicable material specification and the applicable Class (PN). Restrictions on temperature and pressure conditions, for example, those imposed by special soft seals or special trim materials shall be marked on the valve identification plate (see 8.4).

4.2 The temperature for a corresponding pressure rating is the maximum temperature of the pressure-containing shell of the valve. In general, this temperature is the same as that of the contained fluid. The use of a pressure rating corresponding to a temperature other than that of the contained fluid is the responsibility of the user.

4.3 For temperatures below the lowest temperature listed in the pressure/temperature tables (see 4.1), the service pressure shall be no greater than the pressure for the lowest listed temperature. The use of valves at lower temperatures is the responsibility of the user. Consideration should be given to the loss of ductility and impact strength of many materials at low temperature.

5 Design

5.1 Body wall thickness

5.1.1 A valve body schematic is shown in Figure 1. The minimum body wall thickness, t_m , at the time of manufacture shall be as given in table 1, except as indicated in 5.1.2 for butt-welding valve ends. Additional metal thickness needed for assembly stresses, stress concentrations, and shapes other than circular shall be determined by individual manufacturers since these factors vary widely.

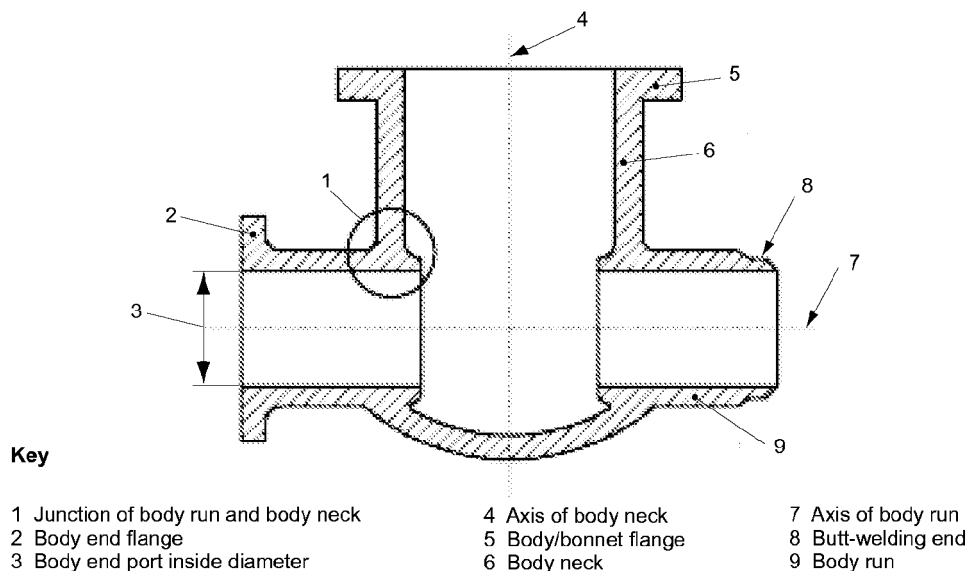

Figure 1 — Identification of terms

5.1.2 The weld end preparation in butt-welding end valves (see 5.3.2) shall not reduce the body wall thickness to less than the values specified in 5.1.1 within a region closer to the outside surface of the body neck than t_m measured along the run direction. The transition to the weld preparation shall be gradual and the section shall be essentially circular through the entire length of the transition. Sharp discontinuities or abrupt changes in section in areas that infringe into the transition shall be avoided, except for test collars or bands, either welded or integral. In no case shall the thickness be less than $0,77t_m$ at a distance of $1,33t_m$ from the weld end.

5.2 Bonnet wall thickness

The minimum bonnet wall thickness at the time of manufacture, except for the neck extension which forms the stem and packing entry-way, shall be t_m as given in table 1. For the stem and packing entry-way the local minimum wall thickness shall be based on the local diameter, e.g., the diameter of the stem bore or packing box bore, and shall be in accordance with table 2.

Table 1 — Minimum wall thickness for body and bonnet

Nominal size DN	PN designation						Nominal pipe size NPS
	20	50	110	150	260	420	
	Class designation						
	150	300	600	900	1500	2500	
	Minimum wall thickness, t_m mm						
25	6,4	6,4	7,9	12,7	12,7	15	1
32	6,4	6,4	8,6	14,2	14,2	17,5	1 ¹ / ₄
40	6,4	7,9	9,4	15	15	19,1	1 ¹ / ₂
50	8,6	9,7	11,2	19,1	19,1	22,4	2
65	9,7	11,2	11,9	22,4	22,4	25,4	2 ¹ / ₂
80	10,4	11,9	12,7	19,1	23,9	30,2	3
100	11,2	12,7	16	21,3	28,7	35,8	4
150	11,9	16	19,1	26,2	38,1	48,5	6
200	12,7	17,5	25,4	31,8	47,8	62	8
250	14,2	19,1	28,7	36,6	57,2	67,6	10
300	16	20,6	31,8	42,2	66,8	86,6	12
350	16,8	22,4	35,1	46	69,9	—	14
400	17,5	23,9	38,1	52,3	79,5	—	16
450	18,3	25,4	41,4	57,2	88,9	—	18
500	19,1	26,9	44,5	63,5	98,6	—	20
600	20,6	30,2	50,8	73,2	114,3	—	24

Table 2 — Minimum wall thickness for bonnet neck (packing entry-way)

Stem or packing entryway diameter mm	PN designation					
	20	50	110	150	260	420
	Class designation					
	150	300	600	900	1 500	2 500
	Minimum wall thickness, ^{a)} t_m mm					
15	2,8	3	3,6	4,2	5,3	7,6
16	2,8	3,1	3,6	4,4	5,6	7,9
17	2,8	3,2	3,7	4,5	5,8	8,2
18	2,9	3,5	3,9	4,7	5,9	8,5
19	3	3,8	4,1	5,1	6,1	8,9
20	3,3	4	4,2	5,2	6,3	9,2
25	4	4,8	4,8	6,3	7,1	11
30	4,6	4,8	4,8	6,5	8,2	13,1
35	4,8	4,8	5,1	7,1	9,7	14,6
40	4,9	5	5,7	7,5	10,2	16,4
50	5,5	6,2	6,3	7,9	11,6	19,8
60	5,6	6,4	6,8	8,9	13,4	23,2
70	5,6	6,9	7,4	9,9	15,8	26,5
80	5,8	7,2	8,1	11	17,4	30,1
90	6,4	7,4	8,8	12	19,1	33,2
100	6,4	7,7	9,5	12,8	20,8	36,7
110	6,4	8,1	10,3	14,1	22,9	40,1
120	6,6	8,6	10,9	14,9	24,8	43,5
130	7,1	8,8	11,3	16,2	26,5	46,9
140	7,1	9,2	12	17,3	28,3	50,2

a) See 5.2.

5.3 Body dimensions

5.3.1 Flanged ends

5.3.1.1 Body end flanges Class 150 through 2500 (PN 20 through 420) shall comply with the dimensional requirements of ASME B16.5 or Series 1 of ISO 7005-1, whichever is the most recent date, except that Class-designated valves shall have inch bolt holes in accordance with ASME B16.5 and PN designated valves shall have metric-sized hole in accordance with ISO 7005-1. Unless otherwise specified, facing finish of the end flanges shall

be in accordance with ASME B16.5 or ISO 7005-1, whichever is the most recent date. Unless otherwise specified, raised face end flanges shall be provided.

5.3.1.2 Face-to-face dimensions for flanged end valves Class 150, 300 and 600 (PN 20, PN 50, and PN 110) shall be in accordance with ASME B16.10 or ISO 5752, basic series 3, 4 and 5, whichever is of the most recent date, except that the applicable tolerance shall be in accordance with the note in table 3. For Class > 600 (PN > 110), the face-to-face dimensions shall be the same as the end-to-end dimensions given in table 3.

5.3.1.3 Body end flanges and bonnet flanges shall be cast or forged integral with the body. However, when specified by the purchaser, forged flanges may be attached by welding by a qualified welding operator using a qualified welding procedure; in this case all flanges attached by welding shall use a butt-welded joint. Heat treatment to ensure that the material is suitable for the full range of service conditions shall be performed in accordance with the material specifications.

Table 3 — End-to-end dimensions for butt-welding end valves

Nominal size DN	PN designation						Nominal pipe size NPS
	20	50	110	150	260	420	
	Class designation						
	150	300	600	900	1500	2500	
	Minimum wall thickness, t_m mm						
25	127	165	216	254	254	308	1
32	140	178	229	279	279	348	1 ¹ / ₄
40	165	190	241	305	305	384	1 ¹ / ₂
50	216	216	292	368	368	451	2
65	241	241	330	419	419	508	2 ¹ / ₂
80	283	283	356	381	470	578	3
100	305	305	432	457	546	673	4
150	403	403	559	610	705	914	6
200	419	419	660	737	832	1 022	8
250	457	457	787	838	991	1 270	10
300	502	502	838	965	1 130	1 422	12
350	572	762	889	1 029	1 257	—	14
400	610	838	991	1 130	1 384	—	16
450	660	914	1 092	1 219	1 537	—	18
500	711	991	1 194	1 321	1 664	—	20
600	813	1 143	1 397	1 549	1 943	—	24

NOTE: The tolerance applicable to the above dimensions is:
 — for DN ≤ 250: ± 2 mm
 — for DN ≥ 300: ± 3 mm

5.3.2 Butt-welding ends

5.3.2.1 Butt-welding ends shall be in accordance with the details shown in figure 2, unless otherwise specified by the purchaser.

5.3.2.2 End-to-end dimensions for butt-welding end valves shall be in accordance with table 3, unless otherwise specified by the purchaser.

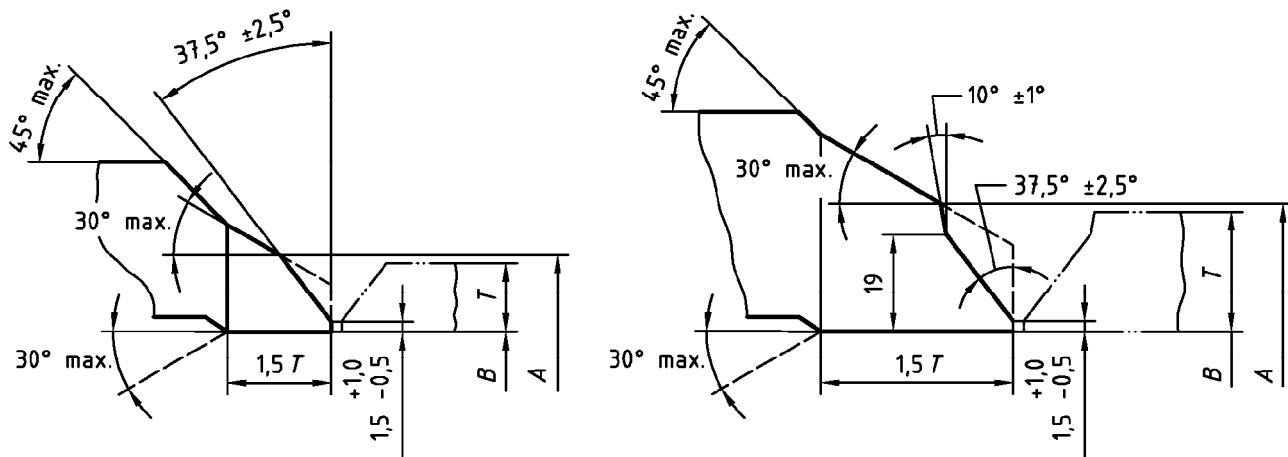

a) Welding end for connection to pipe of wall thickness $T \leq 22$ mm

b) Welding end for connection to pipe of wall thickness $T > 22$ mm

A = nominal outside diameter of welding end

B = nominal inside diameter of pipe

T = nominal wall thickness of pipe

Nominal size, DN	25	32	40	50	65	80	100	150	200	250	300	350	400	450	500	600	
Nominal pipe size, NPS	1	1 1/4	1 1/2	2	2 1/2	3	4	6	8	10	12	14	16	18	20	24	
A, mm	nominal	35	44	50	62	78	91	117	172	223	278	329	362	413	464	516	619
	tolerance	+2.5 -1.0						+4 -1									
B, mm	tolerance	+1 -1						+2 -2			+3 -2						

NOTES

- 1 The inside and outside surfaces of valve welding ends shall be machine finished overall. The contour within the envelope is at the option of the manufacturer unless specifically ordered otherwise.
- 2 Intersections should be slightly rounded.
- 3 Valves with minimum wall thickness equal to 3 mm or less may have ends cut square or slightly chamfered.
- 4 For nominal outside diameters and wall thickness of standard steel pipe, see ISO 4200.

Figure 2 — Weld ends

5.3.3 Body seats

5.3.3.1 The inside diameter of the body seat, except for assembly drive lugs on threaded seat rings, shall not be less than the values specified in table 4.

Table 4 — Body port diameter

Nominal size DN	PN designation						Nominal pipe size NPS
	20	50	110	150	260	420	
	Class designation						
	150	300	600	900	1500	2500	
	Minimum port diameter mm						
25	25	25	25	22	22	19	1
32	31	31	31	28	28	25	1 ¹ / ₄
40	38	38	38	34	34	28	1 ¹ / ₂
50	50	50	50	47	47	38	2
65	63	63	63	57	57	47	2 ¹ / ₂
80	76	76	76	72	69	57	3
100	100	100	100	98	92	72	4
150	150	150	150	146	136	111	6
200	200	200	199	190	177	146	8
250	250	250	247	238	222	184	10
300	300	300	298	282	263	218	12
350	336	336	326	311	288	241	14
400	387	387	374	355	330	276	16
450	438	431	419	400	371	311	18
500	488	482	463	444	415	342	20
600	590	584	558	533	498	412	24

5.3.3.2 Integral body seats are permitted in austenitic stainless steel valves. When an austenitic stainless steel or a hard-facing material is used for the body seat, this material may be weld deposited directly on the valve body. Otherwise, valve bodies shall have separate shoulder or bottom seated seat rings that are either threaded or welded in place except that for DN ≤ 50, rolled or pressed in seat rings may be used.

5.3.3.3 Body seating surfaces shall not have sharp corners at either the inner or outer seat circumference.

5.3.3.4 Sealing compounds or greases shall not be used when assembling seat rings. However, a light lubricant having a viscosity no greater than kerosene may be used to prevent galling of mating threaded surfaces.

5.3.4 Openings

Tapped openings are prohibited unless specified by the purchaser. All openings shall be in accordance with 5.12. When tapped openings are permitted for testing, they shall not be larger than DN 15.

5.4 Bonnet dimensions

5.4.1 The bonnet stem hole shall be designed to have proper clearance for stem guiding and for the prevention of packing extrusion.

5.4.2 The bonnet shall include a conical stem backseat in one of the following forms:

- a bushing;
- an integral surface in the case of an austenitic stainless steel valve;
- an austenitic stainless steel or hardface weld deposit with a minimum thickness of 1,6 mm.

5.4.3 The restrictions of 5.3.4 on openings also apply to the bonnet.

5.4.4 Bonnets shall be one piece castings or forgings subject to the same requirements and exceptions as specified in 5.3.1.3.

5.4.5 The gland bolting shall not be anchored to the bonnet or yoke through a fillet welded attachment or stud welded pins. The anchor design shall not include slotted holes or brackets which do not shackle gland bolting during repacking.

5.5 Bonnet-to-body joint

5.5.1 The bonnet-to-body joint shall be a flange and gasket type.

5.5.2 For PN 20 valves, the bonnet-to-body joint shall be one of the following types which are illustrated in figure 5 of ISO 7005-1:1992:

- Type A, flat face;
- Type B, raised face;
- Types C and D, tongue and groove;
- Types E and F, spigot and recess;
- Type J, ring joint.

5.5.3 For valves having nominal pressure greater than PN 20 the bonnet-to-body joint shall be in accordance with 5.5.2, except that the Type A, flat face, joint is not permitted.

5.5.4 The bonnet flange gasket shall be suitable for the temperature range – 29°C to 538°C and shall be one of the following:

- solid metal, corrugated or flat;
- filled metal jacketed, corrugated or flat;
- metal ring joint;

- spiral wound metal gasket with filler and a centring/compression ring;
- spiral wound metal gasket with filler to be used only in a bonnet-to-body joint design that provides gasket compression control.

For PN 20, the following may also be used:

- flexible graphite sheet reinforced with a stainless steel flat, perforated, tanged or corrugated insert.

5.5.5 Except for all PN 20 valves and all valves in sizes DN 65 and smaller, bonnet-to-body flanges shall be circular.

5.5.6 Bonnet and body flange nut bearing surfaces shall be parallel to the flange face within $\pm 1^\circ$. Spot facing or backfacing required to meet the parallelism requirement shall be in accordance with either ASME B16.5 or ISO 7005-1.

5.5.7 The bonnet-to-body joint shall be secured by a minimum of four through-type stud bolts. The minimum stud bolt size, for each valve size, in accordance with its PN or Class designation, shall be as follows:

- M10 or 3/8 when $25 \leq DN \leq 65$;
- M12 or 1/2 when $80 \leq DN \leq 200$;
- M16 or 5/8 when $250 \leq DN$.

5.5.8 Valve bonnet bolting shall, as a minimum, meet the following bolt cross-sectional area requirements:

$$6k(\text{PN}) \frac{A_g}{A_b} \leq 65.26S_b \leq 9000 \quad \text{or} \quad \text{Class} \frac{A_g}{A_b} \leq 65.26S_b \leq 9000$$

where

S_b is the allowable bolt stress at 38°C, in megapascals (when greater than 138 MPa, use 138 MPa);

PN is the nominal pressure designation number;

Class is the class rating number;

A_g is the area bounded by the effective outside periphery of the gasket in square millimeters, except that in the case of a ring joint the bounded area is defined by the pitch diameter of the ring;

A_b is the total effective bolt tensile stress area, in square millimeters;

k is a coefficient having the following value:

$$k = 1,25 \text{ when PN} = 20;$$

$$k = 1 \text{ when PN} = 50;$$

$$k = 0,91 \text{ when PN} = 110;$$

$$k = 1 \text{ when PN} = 150;$$

$k = 0,97$ when $PN = 260$;

$k = 1$ when $PN = 420$.

5.5.9 At assembly, all gasket contact surfaces shall be free of heavy oils, grease and sealing compounds. A light coating of a lubricant, no heavier than kerosene, may be applied if needed to assist in proper gasket assembly.

5.6 Gate

5.6.1 Gate configurations are categorized as illustrated in Annex B.

5.6.1.1 A one-piece wedge gate, as either a solid or flexible wedge design, shall be furnished unless otherwise specified.

5.6.1.2 A two-piece split wedge gate or parallel seat double disc gate may be furnished when specified. A split wedge gate consists of two independent seating parts that conform to the body seats when closed. A double disc gate has a spreading mechanism that forces the two parallel discs to the body seats when closed.

5.6.2 Except for a double disc gate, in the open position, the gate shall completely clear the valve seat openings.

5.6.3 Gates shall be designed so that all parts can function properly independent of the installed valve orientation.

5.6.4 Guides shall be provided in the gate and the shell and shall be designed so as to minimize seat wear and maintain gate to stem alignment in all valve orientations. Gate-to-shell design shall consider wear that may be caused by corrosion, erosion and abrasion.

5.6.5 Gate seating surfaces shall be integral or faced with weld metal. Unless specified, hard faced seating surfaces are not required. Finished thickness of any facing material shall be not less than 1,6 mm.

5.6.6 Wedge gates shall be designed to account for seat wear. The dimensions that fix the position of the gate seats relative to the body seats shall be such that the gate, starting from the time of manufacture, can move into the seats, as a result of seat wear, a distance defined as wear travel. The required minimum wear travel varies with valve size, as given in table 5.

Table 5 — Minimum wear travel

Valve size range DN	Minimum wear travel mm
$25 \leq DN \leq 50$	2,3
$65 \leq DN \leq 150$	3,3
$200 \leq DN \leq 300$	6,4
$350 \leq DN \leq 450$	9,7
$500 \leq DN \leq 600$	12,7

5.7 Yoke

5.7.1 The yoke may be either an integral part of the bonnet or a separate part. The yoke shall retain the stem nut which links the handwheel to the stem.

5.7.2 Yokes shall be designed so as to allow the stem nut to be removed when the valve is under pressure without removing the bonnet from the valve body.

5.7.3 Yokes that are separate shall have yoke-to-bonnet mating surfaces machined so as to assure a proper bearing assembly interface.

5.7.4 The yoke-to-stem nut bearing surfaces shall be machined flat and parallel. A lubricating fitting shall be provided for the bearing surfaces.

5.8 Stem and stem nut

5.8.1 The minimum stem diameter, d_s , at the time of manufacture shall be in accordance with table 6. The minimum stem diameter applies to the stem in the packing area and to the major diameter of the trapezoidal stem thread. However, the major diameter of the stem thread may be reduced, at the manufacturer's option, by no more than 1.6 mm. The stem surface area in contact with the packing shall have a surface finish, R_a of 0.80 μm or smoother.

5.8.2 Stems shall have a gate attachment means at one end and an external trapezoidal style thread form at the other. Stem nuts shall be used for handwheel attachment and to drive the operating stem thread.

5.8.3 The stem-to-stem nut threads shall be of trapezoidal form as specified in ASME B1.5 or ASME B1.8, with nominal dimensional variations allowed. Stem threads shall be left-handed so that a direct operated handwheel rotated in a clockwise direction will close the valve.

5.8.4 The stem shall be one-piece wrought material. Welded fabrication is not permitted.

5.8.5 The stem end that connects to a gate shall be in the form of a tee. However, for a double disc gate, the end connection may be threaded.

5.8.6 The stem connection shall be designed to prevent the stem from turning or from becoming disengaged from the gate while the valve is in service.

5.8.7 The stem design shall be such that the strength of the stem to gate connection and the part of the stem within the valve pressure boundary shall, under axial load, exceed the strength of the stem at the root of the operating thread.

5.8.8 The one-piece stem shall include a conical or spherical raised surface that will seat against the bonnet backseat when the gate is at its full open position. A stem-bonnet backseat is a requirement of this International Standard, and as such, is not meant to imply a manufacturer's recommendation that it may be used for the purpose of adding or replacing packing while the valve is under pressure.

5.8.9 The stem nut design shall allow for the removal of the handwheel while keeping the stem (and disc) in a fixed position.

5.8.10 The stem nut-to-handwheel attachment shall be through a hexagonal interface, a round interface having a keyway or another means of equivalent strength and durability.

5.8.11 When the stem nut is retained in the yoke by means of a threaded bushing, the bushing shall be secured in place using either a lock weld or a positive mechanical lock. Locking by simple metal upsetting such as peening or staking is not permitted.

5.8.12 The closed-position stem thread projection beyond the stem nut on a new valve shall be a distance having a minimum equal to the valve wear travel and a maximum of five times the wear travel for DN 150 valves or smaller and three times the wear travel for valves larger than DN 150.

5.8.13 Valves DN 150 or larger with PN 110 or greater, shall be furnished with stem nuts having ball or roller bearings.

Table 6 — Minimum stem diameter

Nominal size DN	PN 20	PN 50	PN 110	PN 150	PN 260	PN 420	Nominal pipe size NPS
	Class 150	Class 300	Class 600	Class 900	Class 1500	Class 2500	
Minimum stem diameter, d_s mm							
25	15,59	15,59	15,59	18,77	18,77	18,77	1
32	15,59	15,59	15,59	18,77	18,77	18,77	1 ¹ / ₄
40	17,17	18,77	18,77	21,87	21,87	21,87	1 ¹ / ₂
50	18,77	18,77	18,77	25,04	25,04	25,04	2
65	18,77	18,77	21,87	28,22	28,22	28,22	2 ¹ / ₂
80	21,87	21,87	25,04	28,22	31,39	31,39	3
100	25,04	25,04	28,22	31,39	34,47	34,47	4
150	28,22	31,39	37,62	40,77	43,84	46,94	6
200	31,39	34,47	40,77	46,94	53,24	59,54	8
250	34,47	37,62	46,94	53,24	62,74	72,24	10
300	37,62	40,77	50,14	56,44	69,14	81,84	12
350	40,77	43,84	56,44	59,54	75,44	—	14
400	43,84	46,94	59,54	62,74	75,44	—	16
450	46,94	50,14	62,74	69,14	—	—	18
500	50,14	53,24	69,14	75,44	—	—	20
600	56,44	62,74	75,44	—	—	—	24

5.9 Packing and packing box

5.9.1 The packing may be either square or rectangular in cross-section. The nominal radial width of the packing shall be in accordance with table 7.

Table 7 — Nominal radial width of the packing

Nominal stem diameter, d mm	Nominal radial width of the packing, w mm
$15 \leq d \leq 27$	6,4
$27 \leq d \leq 37$	7,9
$37 \leq d \leq 49$	9,5
$49 \leq d \leq 56$	11,1
$56 \leq d \leq 74$	12,7
$74 < d$	14,3

5.9.2 The nominal depth of the packing box shall accommodate a minimum of five uncompressed rings of packing. Unless otherwise specified, the packing box surface area in contact with the packing material shall have a surface finish R_a of 3.2 μm or smoother.

5.9.3 The nominal bore of the packing box shall be equal to the nominal stem diameter plus twice the nominal packing width plus 0,8 mm (i.e. $d + 2w + 0,8$).

5.9.4 A gland and a separate gland flange shall be provided for packing compression. The upper end of the gland shall have a lip whose outer diameter exceeds the diameter of the packing box bore so as to block entry into the bore. The gland flange shall have two holes to receive the gland bolting. Gland flange bolt slots shall not be used.

5.9.5 The packing gland shall be flanged with two holes for the gland bolts (slots for gland bolts shall not be used). The gland and gland flange shall be self aligning. The gland shall have a shoulder at its outer edge so as to prevent complete entry of the gland into the packing box.

5.9.6 A lantern ring shall be provided only if so specified by the purchaser. The lantern ring shall have two holes located 180° apart on each end to facilitate its removal. These holes may be either through holes for use with a hook or threaded holes of the 1/2-course thread series (NO. 5-40 UNC) as specified in ASME B1.1. When a lantern ring is installed, the packing box shall be tapped opposite the center of the installed lantern ring and shall be fitted with a threaded round or hexagon head plug greater than or equal to DN 8 (NPS 1/4). The plug shall be in accordance with ASME B16.11. The packing box shall have a boss as specified in 5.12, proportioned for sizes not listed. In order to accommodate the lantern ring, the stuffing box depth shall be at least equivalent to that of a minimum three uncompressed rings of packing above the lantern ring and three uncompressed rings of packing below the lantern ring plus the length of the lantern ring.

5.10 Bolting

5.10.1 Bonnet-to-body joint bolting shall be continuously threaded stud bolts with heavy, semi-finished hexagon nuts that are in accordance in with ASME B18.2.2.

5.10.2 Yoke-to-bonnet bolting shall be either continuously threaded stud bolts or headed bolts with hexagon nuts.

5.10.3 Gland bolts shall be hinged eyebolts, headed bolts, stud bolts or studs. Hexagon nuts shall be used.

5.10.4 Bolting 25 mm and smaller shall have coarse (UNC) threads or the most nearly corresponding metric threads. Bolting larger than 25 mm shall be 8 thread series (8UN) or the most nearly corresponding metric threads. Bolt threads shall be Class 2A and nut threads shall be Class 2B, in accordance with ASME B1.1. Studs used for gland bolting shall use a Class 5 interference fit conforming to ASME B1.12.

5.11 Operation

5.11.1 Unless otherwise specified by the purchaser, the valve shall be supplied with a direct operated handwheel that opens the valve when turned in a counter-clockwise direction.

5.11.2 The handwheel shall be a spoke-rim type with a maximum of six spokes and shall be free from burrs and sharp edges. Unless otherwise specified, the handwheel shall be a one piece casting or forging or a multi-piece carbon steel fabrication that includes other carbon steel product forms. Fabricated handwheels shall have strength and toughness characteristics comparable to that of handwheels made as one piece castings or forgings.

5.11.3 The handwheel shall be marked with the word "OPEN" and an arrow pointing in the direction of opening except when the handwheel size makes such marking impractical.

5.11.4 The handwheel shall be retained on the stem nut by a threaded handwheel nut.

5.11.5 If operation by a chainwheel, gearbox or power actuator is to be added to the valve, the purchaser shall

specify the following, as applicable:

- for chainwheel operation the dimension from the centreline of the valve stem to the bottom of the chain loop;
- spur or bevel gear and the position of gearing handwheel relative to the pipe axis;
- electric, hydraulic, pneumatic or other actuator type;
- maximum service temperature and pressure differential across the valve disc;
- power supply attributes for power actuators.

5.11.6 Valve to gear box or power actuator mating dimensions may be according to ISO 5210 or shall comply with the purchaser's specifications.

5.12 Auxiliary connections

5.12.1 Auxiliary connections are not required, except when specified by the purchaser.

5.12.2 Unless the purchaser specifies otherwise, the minimum nominal pipe size for auxiliary connections shall be in accordance with table 8.

Table 8 — Auxiliary connection size

Valve size range DN	Minimum connection size	
	DN	NPS
$50 \leq \text{DN} \leq 100$	15	$1/2$
$150 \leq \text{DN} \leq 200$	20	$3/4$
$250 \leq \text{DN} \leq 600$	25	1

5.12.3 Auxiliary connections shall be identified as indicated in figure 3. Each of the 11 locations is designated by a letter.

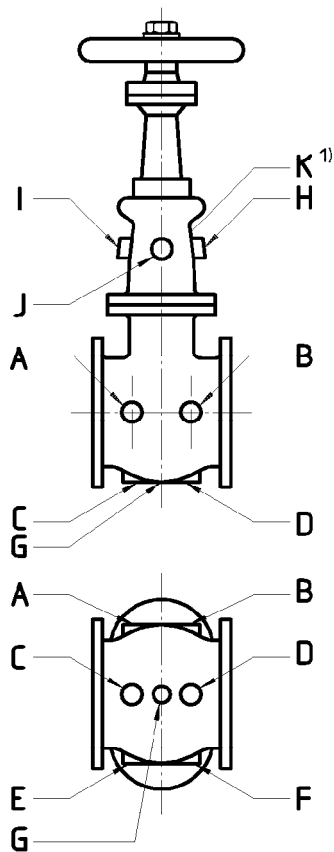

NOTE:
1) On same side as E and F.

Figure 3 — Location of tapings for auxiliary connections

5.12.4 When bosses require additional metal thickness to obtain adequate metal wall thickness, the minimum inscribed diameter of the boss shall be in accordance with table 9.

Table 9 — Minimum boss diameter

Auxiliary connection size		Minimum boss diameter mm
DN	NPS	
15	1/2	38
20	3/4	44
25	1	54
32	1 1/4	64
40	1 1/2	70

5.12.5 The wall of the valve may be tapped if the metal thickness is thick enough to allow the effective thread length, *L*, shown in figure 4 and given in table 10. Where the thread length is insufficient or the tapped hole needs reinforcement, a boss shall be added as specified in 5.12.4. Pipe threads shall be of the taper style shown in figure 4.

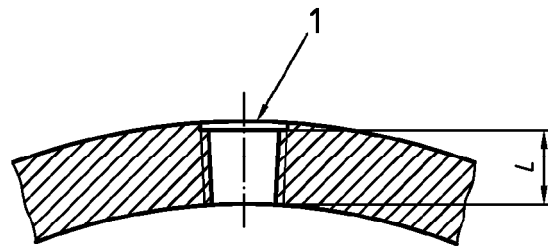

NOTE:

1 Pipe thread ASME B1.20.1 or pipe thread ISO 7-1 Rc.

Figure 4 — Thread length for auxiliary connections

Table 10 — Minimum thread length

Auxiliary connection size		Minimum thread length <i>L</i> mm
DN	NPS	
15	1/2	14
20	3/4	14
25	1	18
32	1 1/4	18
40	1 1/2	19

5.12.6 Sockets, for socket welding connections, may be provided if the metal is thick enough to accommodate the depth of socket and remaining wall shown in figure 5 and given in table 11. If the wall thickness is insufficient for the socket welding connection, a boss shall be added as specified in 5.12.4. The length of the leg of the connection attachment weld shall be 1,09 times the nominal pipe wall thickness of the auxiliary connection or 3 mm, whichever is the greater.

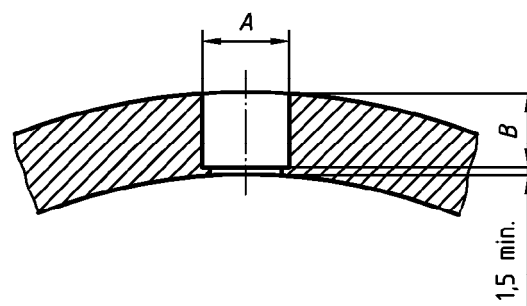

Figure 5 — Socket welding for auxiliary connections

Table 11 — Socket dimensions

Auxiliary connection size		A_{min}	B_{min}
DN	NPS	mm	mm
15	1/2	22	5
20	3/4	27	6
25	1	34	6
32	1 1/4	43	6
40	1 1/2	49	6

5.12.7 Auxiliary connections may be attached by butt-welding directly to the wall of the valve as illustrated in figure 6. If the size of the opening is such that reinforcement is necessary, a boss shall be added as specified in 5.12.4.

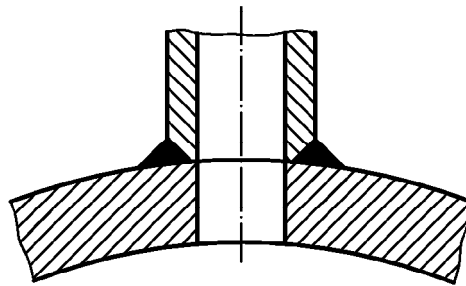

Figure 6 — Butt-welding for auxiliary connections

6 Materials

6.1 Materials other than trim materials

Materials for body, bonnet, and valve parts other than trim items shall be selected from table 12.

6.2 Trim

6.2.1 Trim items include the stem, the gate seat surfaces, the body (or seat ring) seat surfaces and the backseat stem contact surface. The trim materials shall be as in table 13 unless other materials are agreed upon between the purchaser and manufacturer. The trim combination number, CN, identifies both the stem material and the associated seating surfaces.

Table 12 — Materials for parts

Part	Material
Body and bonnet	To be selected from ANSI/ASME B16.34 or ISO 7005-1:1992, table D.2.
Gate	Steel, at least equal in corrosion resistance to that of the body material.
Yoke, separate	Carbon steel or same material as the bonnet.
Bolting: bonnet-to-body	Bolts shall be according to ANSI ASTM A193-87 and nuts shall be according to ANSI ASTM A194-2H. For service temperature below -29°C or above 454°C , the purchase order shall specify the bolting material.
Bolting: gland and yoke	Bolting material at least equal to ANSI ASTM A307-Grade B.
Seat ring	As in table 13. However, when weld deposited facings are used, the base material shall be of similar corrosion resistance as the body material.
Gland flange	Steel.
Gland	Material with melting point above 955°C .
Packing	Suitable for steam and petroleum fluids for temperature range from -29°C to 538°C . Shall contain a corrosion inhibitor.
Stem nut	Austenitic ductile iron or copper alloy with melting point above 955°C .
Handwheel	Malleable iron, carbon steel, or ductile iron.
Handwheel nut (retaining)	Steel, malleable iron, ductile iron, or non-ferrous copper alloy.
Pipe plugs	Nominal composition to be the same as the shell material. Cast iron plugs shall not be used.
Bypass piping and valves	Nominal composition to be the same as the shell material.
Pin, double disk stem to gate	Austenitic stainless steel.
Identification plate	Austenitic stainless steel or nickel alloy attached to the valve by corrosion-resistant fasteners or by welding.
Lantern ring	A material that has a corrosion resistance is at least equal to that of the body material.
Bonnet Gasket	The metallic portion exposed to the service environment shall be of a material that has a corrosion resistance at least equal to that of the body material.

Table 13 — Basic trim materials

Part	Combination number	Material description	Brinell hardness
Stem ¹⁾	1 and 4 through 8A	13Cr	200 HB min. 275 HB max.
	2	18Cr – 8Ni	3)
	3	25 Cr – 20Ni	3)
	9 or 11	NiCu alloy	3)
	10 or 12	18Cr – 8Ni – Mo	3)
	13 or 14	19Cr – 29Ni	3)
Seating surfaces ²⁾	1	13Cr	250 HB min.
	2	18Cr – 8Ni	3)
	3	25Cr – 20Ni	3)
	4	13Cr	750 HB min.
	5 or 5A	HF	350 HB min.
	6	13Cr/ CuNi	250 HB min. 175 HB min.
	7	13Cr/ 13Cr	250 HB min. 750 HB min.
	8 or 8A	13Cr/ HF	250 HB min. 350 HB min.
	9	NiCu alloy	3)
	10	18Cr – 8Ni – Mo	3)
	11 or 11A	NiCu alloy/ HF	3) 350 HB min.
	12 or 12A	18Cr – 8Ni – Mo/ HF	3) 350 HB min.
	13	19Cr – 29Ni	3)
	14 or 14A	19Cr – 29Ni/ HF	3) 350 HB min.
<p>NOTES</p> <p>1) Stems shall be wrought material.</p> <p>2) Backseat surfaces for CN 1 and 4 through 8A shall have a minimum hardness of 250 HB.</p> <p>3) Not specified.</p> <p>1 Cr = chromium; Ni = Nickel; Co = cobalt; Mo = Molybdenum.</p> <p>2 HF = Hard Facing using CoCr or NiCr welding alloy. The suffix A applies to NiCr.</p> <p>3 Free machining grades of 13 Cr shall not be used.</p> <p>4 For CN 1, a differential hardness of at least 50 Brinell points is required between mating surfaces.</p> <p>5 When two materials are separated by a slash this denotes two separate materials, one for the seat ring seating surface and the other for the gate seating surface without implying a preference for which is to be applied to other part.</p>			

6.2.2 The trim material shall be the manufacturer's standard trim material for the combination number, CN, specified in the purchase order. For a CN specified in a purchase order an alternative CN may be furnished in accordance with table 14.

Table 14 — Combination numbers

Specified CN	Alternative CN
1	8 or 8A
2	10
5A	5
6	8
8A	8

It is not permissible to furnish a Specified CN when an Alternative CN is specified in a purchase order without agreement from the purchaser.

6.3 Repair

Defects in the cast or forged valve pressure shell materials that are revealed during manufacturing operations or testing may be repaired as permitted by the most nearly applicable specification for forgings or castings.

7 Testing, inspection and examination

7.1 Pressure tests

Each valve shall be given a shell pressure test, a closure tightness test and a stem backseat test in accordance with the requirements of ISO 5208, except as modified herein. Sealing compounds, greases or oils shall be removed from seating surfaces prior to pressure testing. It is permissible, however, for a film of oil that is not heavier than kerosene to be applied to prevent sealing surfaces from galling.

7.1.1 Shell test

7.1.1.1 The shell test shall be at a pressure no less than 1,5 times the pressure corresponding to the valve 38°C pressure rating. The packing gland shall be adjusted so as to maintain the test pressure.

7.1.1.2 The duration of the shell test and the minimum period of time that the shell test pressure is to be sustained, shall be in accordance with table 15.

Table 15 — Duration of the shell test

Valve size range DN	Test duration s
DN ≤ 50	15
65 ≤ DN ≤ 150	60
200 ≤ DN ≤ 300	120
350 ≤ DN	300

7.1.1.3 Over the duration of the shell test there shall be no visually detectable leakage through the shell wall or at the bonnet gasket.

7.1.2 Closure tightness test

7.1.2.1 The closure tightness test for each valve shall be as follow:

—for valves DN ≤ 100 with Class ≤ 1500 (PN ≤ 260) and for valves DN > 100 with Class ≤ 600 (PN ≤ 110), a gas test with the test gas at a pressure between 4 bar and 7 bar (400 kPa and 700kPa) or

—for valves DN ≤ 100 with Class > 1500 (PN > 260) and for valves DN > 100 with Class > 600 (PN > 110), a liquid test with the test fluid at a pressure not less than 1.1 times the maximum allowable valve pressure rating at 38°C.

7.1.2.2 A closure test shall be applied one direction at a time for each seating direction. The test method shall include the filling and pressurizing the body cavity between the seats and the bonnet with test fluid so as to ensure that no seat leakage can escape detection.

7.1.2.3 The duration of the closure tightness test, the minimum period of time that the test pressure is to be sustained for the purpose of obtaining a seat closure tightness leakage measurement, shall be in accordance with table 16.

Table 16 — Duration of the closure test

Valve size range DN	Test duration s
DN ≤ 50	15
65 ≤ DN ≤ 150	60
200 ≤ DN ≤ 300	120
350 ≤ DN	120

7.1.2.4 Over the duration of the closure tightness test, the maximum permitted leakage rate past the valve seats, shall be in accordance with table 17 or table 18 as applicable. For the gas test, zero leakage is defined as less than 3 mm³ (1 bubble) leakage over the specified test duration. For the liquid test, zero leakage is defined as no visible leakage over the specified test duration.

7.1.2.5 Throughout the duration of the closure test there shall be no visible evidence of leakage through the gate proper or from behind the installed seat rings.

7.1.2.6 When volumetric devices are used to measure seat leakage rates they shall be calibrated to yield results equivalent to those of tables 17 or 18 for the valves under test. These devices shall be calibrated with the same test fluid, at the same temperature, as used for the valve closure tests.

7.1.2.7 Valves for which gas tests are specified in 7.1.2.1 shall have valve closure elements that are designed to sustain pressure loads corresponding to the conditions of the liquid test, 7.1.2.1, and shall have the capability of meeting the leakage requirements specified in table 18 for the liquid test.

Table 17 — Maximum allowable gas leakage rate

Valve size range DN	Maximum allowable gas leakage rate ¹⁾	
	mm ³ /s	bubbles/s
DN ≤ 50	0	0
65 ≤ DN ≤ 150	25	0,4
200 ≤ DN ≤ 300	42	0,7
350 ≤ DN	58	0,9

1) The manufacturer may choose either method of quantifying gas leakage. It is recognised that the unit conversions are inexact.

7.1.3 Backseat test

7.1.3.1 The backseat test shall be either a gas test at the pressure given in 7.1.2.1 or a liquid test at a pressure given in 7.1.2.1. The duration of the backseat test shall be in accordance with 7.1.2.3.

7.1.3.2 The stem backseat shall be engaged and the packing gland bolting shall be loose during the backseat test. Visible backseat leakage is not permitted over the duration of the test.

7.1.3.3 The gland bolting shall be retightened following the backseat test.

7.1.4 Optional closure tightness test

7.1.4.1 A high pressure liquid closure test is not required for all valves, see 7.1.2.1. It is, however, an option that the purchaser may specify. However, as a test of the valve closure structure, all valves are expected to be able to pass this test, see 7.1.2.7.

7.1.4.2 The test fluid shall be at a pressure of 1,1 times the valve pressure rating at 38°C.

7.1.4.3 The duration of the test shall be in accordance with 7.1.2.3.

7.1.4.4 The maximum leakage rate over the duration of the test shall be in accordance with table 18.

Table 18 — Maximum allowable liquid leakage rate

Valve size range DN	Maximum allowable liquid leakage rate ¹⁾	
	mm ³ /s	drops/s
DN ≤ 50	0	0
65 ≤ DN ≤ 150	12,5	0,2
200 ≤ DN ≤ 300	20,8	0,4
350 ≤ DN	29,2	0,5

1) The manufacturer may choose either method of quantifying liquid leakage. It is recognized that the unit conversions are inexact.

7.2 Inspection

7.2.1 At the valve manufacturer's factory

If a purchase order requires purchaser's witnessing of tests and examinations at the valve manufacturer's factory, the purchaser's inspector shall have free access to those parts of the factory concerned with the manufacture of the valves when work on the order is under way.

7.2.2 Other than at the valve manufacturer's factory

If a purchase order requires examinations that includes valve bodies or bonnets manufactured at locations other than the valve manufacturer's factory, these components shall be available for inspection at the location where they are being manufactured.

7.2.3 Extent of inspection

The extent of the purchaser's inspection may be specified in the purchase order and, unless otherwise indicated, shall be limited to the following:

—inspection of the valve assembly to ensure compliance with the specifications of the purchase order which may include the specified nondestructive methods of examination.

—witnessing the required and, if specified, optional pressure tests and examinations.

—review of mill test reports and, if specified, nondestructive examination records and radiographs.

7.3 Examination

7.3.1 For each valve, the items listed in Annex A shall be checked by the manufacturer before release for shipment.

7.3.2 The valve manufacturer shall perform a visual examination of the surfaces of castings used for bodies, bonnets, and gates in order to ensure that the requirements of standard MSS SP-55 have been met.

7.3.3 The valve manufacturer shall examine each valve to assure compliance with this standard.

7.3.4 All examinations shall be performed in accordance with written procedures that comply with the applicable standards.

7.4 Supplementary examination

Supplementary types of examination are required only if specified in the purchase order. Magnetic particle, radiographic, liquid penetrant and ultrasonic examination of steel castings or forgings may be specified conforming to the purchaser's procedures and acceptance standards or those standardized in ASME B16.34, Part 8.

8 Marking

8.1 Legibility

Each valve manufactured in accordance with this International Standard shall be clearly marked in accordance with ISO 5209, except that the requirements of this subclause shall apply.

8.2 Body marking

8.2.1 For flanged end valves the mandatory body markings, subject to the provisions of 8.2.3 and 8.2.4, shall be as follows:

- manufacturer's name or trade mark;
- body material;
- pressure designation, as either PN followed by the appropriate pressure number (e.g. PN 20 for valves drilled for metric end flange bolting) or pressure Class number (e.g. 150 for valves drilled for inch end flange bolting);
- nominal size, as either DN followed by the appropriate size number (e.g. DN 500 for valves drilled for metric flange bolting) or the NPS number (e.g. 20, for valves drilled for inch end flange bolting).

8.2.2 For butt-welding end valves the mandatory body markings, subject to the provisions of 8.2.4, shall be as follows:

- manufacturer's name or trade mark;
- body material;
- pressure designation, as either PN followed by the appropriate rating number (e.g. PN 20, or pressure Class number, e.g. 150);
- nominal size, as either DN followed by the appropriate size number (e.g. DN 500 or the NPS number, e.g. 20).

8.2.3 Flanged end valves having PN/DN (or Class/NPS) body markings that are cast or forged into the body and are drilled for inch (or metric) end flange bolting shall have the corresponding Class (or PN) number stamped into the rim of each end flange. The stamping shall be located across from the body neck.

8.2.4 For valves smaller than DN 50, if the size or shape of the valve body precludes the inclusion of all the required markings, one or more may be omitted provided that they are shown on the identification plate. The markings which may be omitted are the following:

- nominal size;
- pressure designation;
- body material.

8.3 Ring joint marking

Body end flanges require marking only when the end flanges are grooved for ring joint assembly or when the flange bolt holes are drilled as described in 8.2.3. When grooved for ring joint assembly, the ring joint gasket number (e.g. R25) shall be marked on the rim of both end flanges. For ring joint gasket groove numbers, see ASME B16.5 or ISO 7005-1.

8.4 Identification plate marking

The identification plate marking shall include the following:

- the manufacturer's name;
- pressure rating designation;

- manufacturer's identification number;
- maximum pressure at 38°C;
- limiting temperature, if applicable;
- limiting pressure, if applicable;
- trim identification;
- compliance marking (i.e., API 600/ISO 10434).

9 Preparation for despatch

- 9.1** The valve shall be shipped with the lantern ring, if specified, and the packing installed. The remaining adjustment length of the packing gland at the time of shipment, with the gland tight, shall be greater than 1,5 times the packing width specified in 5.9.1.
- 9.2** Except for austenitic stainless steel valves, unmachined exterior valve surfaces shall be coated with aluminum color paint.
- 9.3** Machined surfaces, including threads, shall be coated with an easily removable rust inhibitor.
- 9.4** Protective covers of wood, wood fibre, plastic or metal shall be securely affixed to the valve ends in order to safeguard the gasket surfaces or weld end preparations. The cover design shall be such that the valve cannot be installed in a pipeline with the protective cover in place.
- 9.5** Any plugs that may be installed in tapped openings shall be fully tightened.
- 9.6** At the time of shipment, the gate shall be in the closed position.
- 9.7** Unless otherwise specified by the purchaser, valves may be shipped loose, palletised or in boxes or crates.

Annex A (informative)

Information to be specified by the purchaser

NOTE —Numbers in brackets are references to subclauses in this International Standard.

Nominal size [1] (DN or NPS):

Pressure designation [1] (PN or Class):

Body ends [5.3]

Butt-welding:

Flanged

Bolt pattern: PN/metric: Class/inch:

Flange type: Raised face: Ring joint:

Other

Wedge style [5.6]:

Auxiliary connections:

Operation other than handwheel [5.11]:

Material [6]

Pressure containing shell [6.1]:

Trim combination number [6.2]:

Bonnet bolting—special high or low temperature:

Optional high pressure obturator tightness test [7.1.4]:

Extent of Inspection [7.2.3]

Annex B (informative) Identification of valve terms

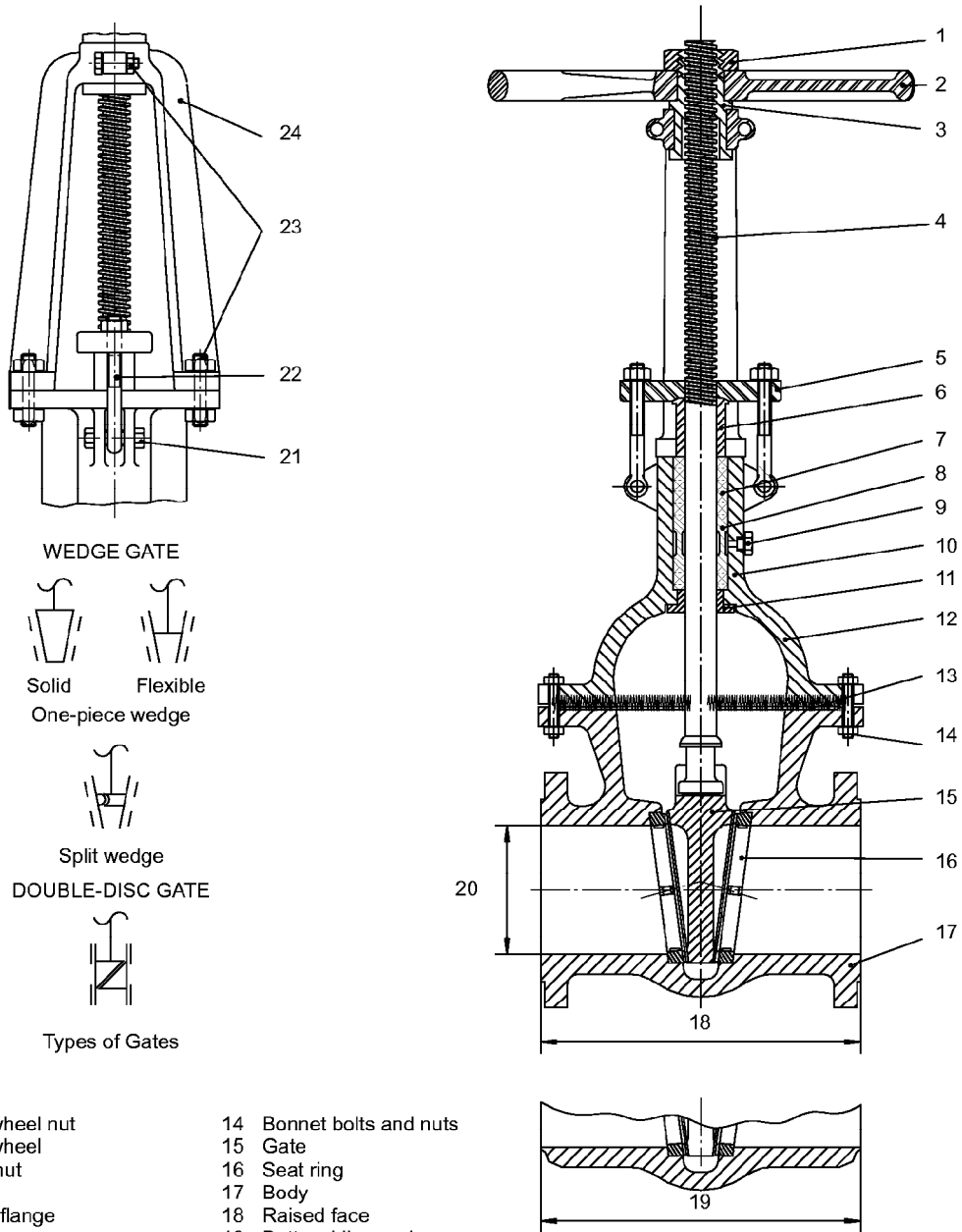

Key

- | | |
|---------------------|---|
| 1 Handwheel nut | 14 Bonnet bolts and nuts |
| 2 Handwheel | 15 Gate |
| 3 Stem nut | 16 Seat ring |
| 4 Stem | 17 Body |
| 5 Gland flange | 18 Raised face |
| 6 Gland | 19 Butt-welding end |
| 7 Stem packing | 20 Valve port |
| 8 Lantern ring | 21 Gland lug bolts and nuts |
| 9 Plug | 22 Gland bolts or gland eyeboils and nuts |
| 10 Wiper packing | 23 Yoke bolting |
| 11 Backseat bushing | 24 Yoke |
| 12 Bonnet | |
| 13 Bonnet gasket | |

NOTE:

The only purpose of this figure is to identify part names. The construction of a valve is acceptable only when it complies with this International Standard in all respects.

Annex C (informative)

Modifications to ISO 10434

The API Manufacturing, Distribution, and Marketing Department, Subcommittee on Piping voted to adopt International Standard, ISO 10434, Bolted bonnet steel gate valves for petroleum and natural gas industries as API 600 subject to the following modifications being incorporated directly into this standard, API 600.¹ These modifications have been embedded into the text of this API 600.

Clause	Type	Modification
2	New	MSS SP-55: 1985 (R 1990) Quality standard for steel castings, visual surface examination.
5.3.1.1	Rev.	Body end flanges, PN 20 through 420 shall comply with the dimensional requirements of ANSI/ASME B16.5 or Series 1 of ISO 7005-1, whichever is of the most recent date, except that Class designated valves shall have inch bolt holes in accordance with ANSI/ASME B16.5 and PN designated valves shall have metric sized hole in accordance with ISO 7005-1. Unless otherwise specified, facing finish of the end flanges shall be in accordance with ANSI/ASME B16.5 or ISO 7005-1, whichever is of the most recent date. Unless otherwise specified, raised face end flanges shall be provided.
5.3.1.2	Rev.	Face-to-face dimensions for flanged end valves, PN 20, PN 50, and PN 110, shall be in accordance with ANSI/ASME B16.10 or ISO 5752, Basic Series 3, 4 and 5, whichever is of the most recent date, except that the applicable tolerance shall be in accordance with the note in table 3. For PN >110, the face-to-face dimensions shall be the same as the end-to-end dimensions given in table 3.
5.4.1	Rev.	The bonnet stem hole shall be designed to have proper clearance for stem guiding and for the prevention of packing extrusion.
5.5.4	Rev.	The bonnet flange gasket shall be suitable for temperature range -29°C to 538°C and be one of the following: —solid metal, corrugated or flat —filled metal jacketed, corrugated or flat —metal ring joint —spiral wound metal gasket with filler and a centering/compression ring —spiral wound metal gasket with filler to be used only in a body-to-bonnet joint design that provides gasket compression control For PN 20, the following may also be used: —flexible graphite sheet reinforced with a stainless steel flat, perforated, tanged or corrugated insert
5.5.8	Edit	Add: $6k(PN)\frac{A_g}{A_b} \leq 65.26S_b \leq 9000$ or (Class) $\frac{A_g}{A_b} \leq 65.26S_b \leq 9000$ Delete: $k(PN)\frac{A_g}{A_b} \leq 11.25S_b \leq 1552 fc$
5.6.1	New	Gate configurations are categorized as illustrated in Annex B.

1. The modifications noted in this Annex align the requirements of ISO 10434 with those of the Tenth Edition of API 600 except that reference to Class 400 valves and API 600, Appendix A, *Requirements for Pressure Seal Valves*, have not been duplicated.

Clause	Type	Modification
5.6.1.1	Rev.	A one piece wedge gate, as either a solid or flexible wedge design, shall be furnished unless otherwise specified.
5.6.1.2	Rev.	A two piece split wedge gate or parallel seat double disc gate may be furnished when specified. A split wedge gate consists of two independent seating parts that conform to the body seats when closed. A double disc gate has a spreading mechanism that forces the two parallel discs to the body seats when closed.
5.6.2	Rev.	Except for a double disc gate, in the open position, the gate shall completely clear the valve seat openings.
5.6.5	Rev.	Gate seating surfaces shall be integral or faced with weld metal. Unless specified, hard faced seating surfaces are not required. Finished thickness of any facing material shall be not less than 1.6 mm.
5.7.2	Rev.	Yokes shall be designed so as to allow the stem nut to be removed when the valve is under pressure without removing the bonnet from the valve body.
5.7.4	Rev.	The yoke-to-stem nut bearing surfaces shall be machined flat and parallel. A lubricating fitting shall be provided for the bearing surfaces.
5.8.1	Rev.	The minimum stem diameter at the time of manufacture shall be as given in table 6. The minimum stem diameter applies to the stem in the packing area and to the major diameter of the trapezoidal stem thread. However the major diameter of the stem thread may be reduced, at the manufacturer's option, by no more than 1.6 mm. The stem surface area in contact with the packing shall have a surface finish, R_a of 0.80 μm or smoother.
5.9.2	Rev.	The nominal depth of the packing box shall accommodate a minimum of five uncompressed rings of packing. Unless otherwise specified, the packing box surface area in contact with the packing material shall have a surface finish, R_a of 3.2 μm or smoother.
5.9.5	Rev.	The packing gland shall be flanged with two holes for the gland bolts (slots for gland bolts shall not be used). The gland and gland flange shall be self aligning The gland shall have a shoulder at its outer edge so as to prevent complete entry of the gland into the packing box.
5.9.6	New	A lantern ring shall be provided only if so specified by the purchaser. The lantern ring shall have two holes located 180 degrees apart on each end to facilitate its removal. These holes may be either through holes for use with a hook or threaded holes of the $1/2$ -course thread series (NO. 5-40 UNC) as specified in ASME B1.1. When a lantern ring is installed, the packing box shall be tapped opposite the center of the installed lantern ring and shall be fitted with a threaded round or hexagon head plug greater than or equal to DN 8 (NPS $1/4$). The plug shall be in accordance with ASME B16.11. The packing box shall have a boss as specified in 5.12, proportioned for sizes not listed. In order to accommodate the lantern ring, the stuffing box depth shall be at least equivalent to that of a minimum three uncompressed rings of packing above the lantern ring and three uncompressed rings of packing below the lantern ring plus the length of the lantern ring.
5.11.2		The handwheel shall be a spoke-rim type with a maximum of six spokes and shall be free from burrs and sharp edges. Unless otherwise specified, the handwheel shall be a one piece casting or forging or a multi-piece carbon steel fabrication that includes other carbon steel product forms. Fabricated handwheels shall have strength and toughness characteristics comparable to that of handwheels made as one piece castings or forgings

Clause	Type	Modification
7	Rev.	7 Testing, inspection and examination
7.1	Edit	Each valve shall be given a shell pressure test, an closure tightness test and a stem backseat test in accordance with the requirements of ISO 5208 except as modified herein. Sealing compounds, greases or oils shall be removed from seating surfaces prior to pressure testing. It is permissible, however, for a film of oil that is not heavier than kerosene to be applied to prevent sealing surfaces from galling.
7.1.2	Edit	7.1.2 Closure tightness test
7.1.2.1	Rev.	The closure tightness test for each valve shall be as follows: — for valves DN ≤ 100 with PN ≤ 260 and for valves DN > 100 with PN ≤ 110, a gas test with the test gas at a pressure between 4 bar and 7 bar (400 kPa and 700 kPa) or — for valves DN ≤ 100 with PN > 260 and for valves DN > 100 with PN > 110, a liquid test with the test fluid at a pressure not less than 1.1 times the maximum allowable valve pressure rating at 38°C. A closure test shall be applied one direction at a time for both (each) seating directions The test method shall include the filling and pressurizing of the body cavity between the seats and the bonnet with test fluid so as to ensure that no seat leakage can escape detection.
7.1.2.3	Edit	The duration of the closure tightness test, the minimum period of time that the test pressure is to be sustained for the purpose of obtaining a seat closure tightness leakage measurement, shall be in accordance with table 16.
7.1.2.4	Rev.	Over the duration of the closure tightness test, the maximum permitted leakage rate past the valve seats shall be in accordance with table 17 or table 18 as applicable. For the gas test, zero leakage is defined as less than 3 mm ³ (1 bubble) leakage over the specified test duration. For the liquid test, zero leakage is defined as no visible leakage over the specified test duration.
7.1.2.5	New	Throughout the duration of the closure test there shall be no visible evidence of leakage through the gate proper or from behind the installed seat rings.
7.1.2.6	New	When volumetric devices are used to measure seat leakage rates they shall be calibrated to yield results equivalent to those of tables 17 or 18 for the valves under test. These devices shall be calibrated with the same test fluid, at the same temperature, as used for the valve closure tests.
7.1.2.7	Rev.	Valves for which gas tests are specified in 7.1.2.1 shall have valve closure elements that are designed to sustain pressure loads corresponding to the conditions of the liquid test, 7.1.2.1, and shall have the capability of meeting the leakage requirements specified in table 18 for the liquid test.
7.1.4.1	Rev.	A high pressure liquid closure test is not required for all valves, see 7.1.2.1. It is, however, an option that the purchaser may specify. However, as a test of the valve closure structure, all valves are expected to be able to pass this test, see 7.1.2.6.
7.1.4.4	Rev.	The maximum leakage rate over the duration of the test shall be in accordance with table 18.
7.2	Rev.	7.2 Inspection
7.2.1	New	7.2.1 At the valve manufacturer's factory If a purchase order requires purchaser's witnessing of tests and examinations at the valve manufacturer's factory, the purchaser's inspector shall have free access to those parts of the factory concerned with the manufacture of the valves when work on the order is under way.

Clause	Type	Modification
7.2.2	New	7.2.2 Other than at the valve manufacturer's factory If a purchase order requires examinations that includes valve bodies or bonnets manufactured at locations other than the valve manufacturer's factory, these components shall be available for inspection at the location where they are being manufactured.
7.2.3	New	7.2.3 Extent of inspection The extent of the purchaser's inspection may be specified in the purchase order and, unless otherwise indicated, shall be limited to the following: —inspection of the valve assembly to ensure compliance with the specifications of the purchase order which may include the specified nondestructive methods of examination; —witnessing the required and, if specified, optional pressure tests and examinations; —review of mill test reports and, if specified, nondestructive examination records and radiographs.
7.3	New	7.3 Examination
7.3.1	New	7.3.1 For each valve, the items listed in Annex A shall be checked by the manufacturer before release for shipment.
7.3.2	New	7.3.2 The valve manufacturer shall perform a visual examination of the surfaces of castings used for bodies, bonnets, and gates in order to ensure that the requirements of standard MSS SP-55 have been met.
7.3.3	New	7.3.3 The valve manufacturer shall examine each valve to assure compliance with this standard.
7.3.4	New	7.3.4 All examinations shall be performed in accordance with written procedures that comply with the applicable standards.
7.4	New	7.4 Supplementary examination
7.4	New	Supplementary types of examination are required only if specified in the purchase order. Magnetic particle, radiographic, liquid penetrant and ultrasonic examination of steel castings or forgings may be specified conforming to the purchaser's procedures and acceptance standards or those standardized in ANSI/ASME B16.34, Part 8.
8.4	New	The identification plate marking shall include: — the manufacturer's name; — pressure designation rating; — manufacturer's identification number; — maximum pressure at 38°C; — limiting temperature, if applicable; — limiting pressure, if applicable; — trim identification; — compliance marking, i.e., API 600/ISO 10434.
Annex B	Rev.	Added details of gate configurations to Annex B.
Table 6	errata	<i>see next page</i>
Table 8	errata	Change the 2nd and 3rd column heading to be "Minimum connection size."
Table 10	errata	Change the title to be "Minimum thread length."

Clause	Type	Modification	
Table 12	add	Lantern ring	A material that has a corrosion resistance is at least equal to that of the body material.
		Gasket	The metallic portion exposed to the service environment shall be of a material that has a corrosion resistance at least equal to that of the body material.
Table 13	add	<i>Under 'NOTES', add a new note #5:</i> 5 When two materials are separated by a slash this denotes two separate materials, one for the seat ring seating surface and the other for the gate seating surface without implying a preference for which is to be applied to either part.	
Table 17	errata	<i>see new below</i>	

Table 6 — Minimum stem diameter

Nominal size DN	PN 20	PN 50	PN 110	PN 150	PN 260	PN 420	Nominal size NPS
	Class 150	Class 300	Class 600	Class 900	Class 1500	Class 2500	
	Minimum stem diameter mm						
25							1
32							1 ¹ / ₄
40							1 ¹ / ₂
50							2
65							2 ¹ / ₂
80							3
100							4
150							6
200					53.24	59.54	8
250				53.24	62.74	72.24	10
300				56.44	69.14	81.84	12
350			56.44	59.54	75.44		14
400			59.54	62.74	75.44		16
450			62.74	69.14			18
500		53.24	69.14	75.44			20
600	56.44	62.74	75.44				24

Note: Shaded values, no change.

Table 17 — Maximum allowable gas leakage rate

Valve size range DN	Maximum allowable gas leakage rate ¹⁾	
	mm ³ /s	bubbles/s
DN ≤ 50	0	0
65 ≤ DN ≤ 150	25	0.4
200 ≤ DN ≤ 300	42	0.7
350 ≤ DN	58	0.9

¹⁾ The manufacturer may choose either method of quantifying gas leakage. It is recognized that the unit conversions are inexact.

American Petroleum Institute

Related Publications Order Form - 2001

Available through Global Engineering Documents

Effective August 1, 2001

Phone Orders: 1-800-854-7179 (Toll-free in the U.S. and Canada) • 303-397-7956 (Local and International) • Fax Orders: 303-397-2740

Online Orders: www.global.ihp.com

Date: _____

API Member (Check if Yes)

Invoice To (Check here if same as "Ship To")

Name _____

Title _____

Company _____

Department _____

Address _____

City _____ State/Province _____

Zip/Postal Code _____ Country _____

Telephone _____

Fax _____

E-Mail: _____

Ship To (US will not deliver to a P.O. Box)

Name _____

Title _____

Company _____

Department _____

Address _____

City _____ State/Province _____

Zip/Postal Code _____ Country _____

Telephone _____

Fax _____

E-Mail: _____

Quantity	Product Number	Title	SO*	Unit Price	Total
	C57002	API 570, Piping Inspection Code: Inspection, Repair, Alteration, and Rerating of In-Service Piping Systems		\$83.00	
	C58902	Std 589, Fire Test for Evaluation of Valve Stem Packing		\$ 50.00	
	C59102	RP 591, User Acceptance of Refinery Valves		\$ 50.00	
	C59405	Std 594, Check Valves: Wafer, Water-Lug and Double Flanged Type		\$ 44.00	
	C59807	Std 598, Valve Inspection and Testing		\$ 46.00	
	C59904	Std 599, Metal Plug Valves—Flanged and Welding Ends		\$ 38.00	
	C60207	Std 602, Compact Steel Gate Valves—Flanged, Threaded, Welding and Extended Body Ends		\$ 46.00	

Payment Enclosed P.O. No. (Enclose Copy) _____

Charge My Global Account No. _____

VISA MasterCard American Express Diners Club Discover

Credit Card No: _____

Print Name (As It Appears on Card): _____

Expiration Date _____

Signature _____

Subtotal

Applicable Sales Tax (see below)

Rush Shipping Fee (see below)

Shipping and Handling (see below)

Total (in U.S. Dollars)

★ To be placed on Standing Order for future editions of this publication, place a check mark in the SO column and sign here:

Pricing and availability subject to change without notice.

Mail Orders - Payment by check or money order in U.S. dollars is required except for established accounts. State and local taxes, \$10 processing fee*, and 5% shipping must be added. Send mail orders to: **API Publications, Global Engineering Documents, 15 Inverness Way East, M/S C303B, Englewood, CO 80112-5776, USA.**

Purchase Orders - Purchase orders are accepted from established accounts. Invoice will include actual freight cost, a \$10 processing fee*, plus state and local taxes.

Telephone Orders - If ordering by telephone, a \$10 processing fee* and actual freight costs will be added to the order.

Sales Tax - All U.S. purchases must include applicable state and local sales tax. Customers claiming tax-exempt status must provide Global with a copy of their exemption certificate.

Shipping (U.S. Orders) - Orders shipped within the U.S. are sent via traceable means. Most orders are shipped the same day. Subscription updates are sent by First-Class Mail. Other options, including next-day service, air service, and fax transmission are available at additional cost. Call 1-800-854-7179 for more information.

Shipping (International Orders) - Standard international shipping is by air express courier service. Subscription updates are sent by World Mail. Normal delivery is 3-4 days from shipping date.

Rush Shipping Fee - Next Day Delivery orders charge is \$20 in addition to the carrier charges. Next Day Delivery orders must be placed by 2:00 p.m. MST to ensure overnight delivery.

Returns - All returns must be pre-approved by calling Global's Customer Service Department at 1-800-624-3974 for information and assistance. There may be a 15% restocking fee. Special order items, electronic documents, and age-dated materials are non-returnable.

***Minimum Order** - There is a \$50 minimum for all orders containing hardcopy documents. The \$50 minimum applies to the order subtotal including the \$10 processing fee, excluding any applicable taxes and freight charges. If the total cost of the documents on the order plus the \$10 processing fee is less than \$50, the processing fee will be increased to bring the order amount up to the \$50 minimum. This processing fee will be applied before any applicable deposit account, quantity or member discounts have been applied. There is no minimum for orders containing only electronically delivered documents.

There's more where this came from.

The American Petroleum Institute provides additional resources and programs to the oil and natural gas industry which are based on API Standards. For more information, contact:

- Monogram Licensing Program
Phone: 202-962-4791
Fax: 202-682-8070
- American Petroleum Institute Quality Registrar (APIQR)
Phone: 202-962-4791
Fax: 202-682-8070
- API Spec Q1 Registration
Phone: 202-962-4791
Fax: 202-682-8070
- Perforator System Registration
Phone: 202-962-4791
Fax: 202-682-8070
- Inspector Certification Programs
Phone: 202-682-8161
Fax: 202-962-4739
- Engine Oil Licensing and Certification System (EOLCS)
Phone: 202-682-8233
Fax: 202-962-4739
- Training Workshops
Phone: 202-682-8490
Fax: 202-962-4797

Check out the API Publications, Programs, and Services Catalog online at www.api.org/cat.

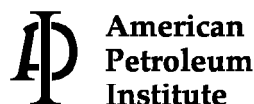

**Helping You
Get The Job
Done Right.SM**

Rev. 09.26.01

Information about API Publications, Programs and Services is available on the World Wide Web at: <http://www.api.org>



**American
Petroleum
Institute**

1220 L Street, Northwest
Washington, D.C. 20005-4070
202-682-8000

Order No. C60011